



# INTEGRATED ACTIVITY BOOK



Latest  
Edition  
\*\*\*\*\*

LKG  
PART - 1



Based on Internationally recommended **MULTIPLE LEARNING PATHWAYS (MLP)** pedagogical principles

Name: \_\_\_\_\_  
Section: \_\_\_\_\_ Roll No.: \_\_\_\_\_  
School: \_\_\_\_\_



## ENGLISH



1. Sounds 3
2. Talking with Actions and Eyes 5
3. Expressions on My Face 9
4. Spotting Differences 11
5. Picture Talk 13
6. Strokes 15
7. Letters of the Alphabet 17

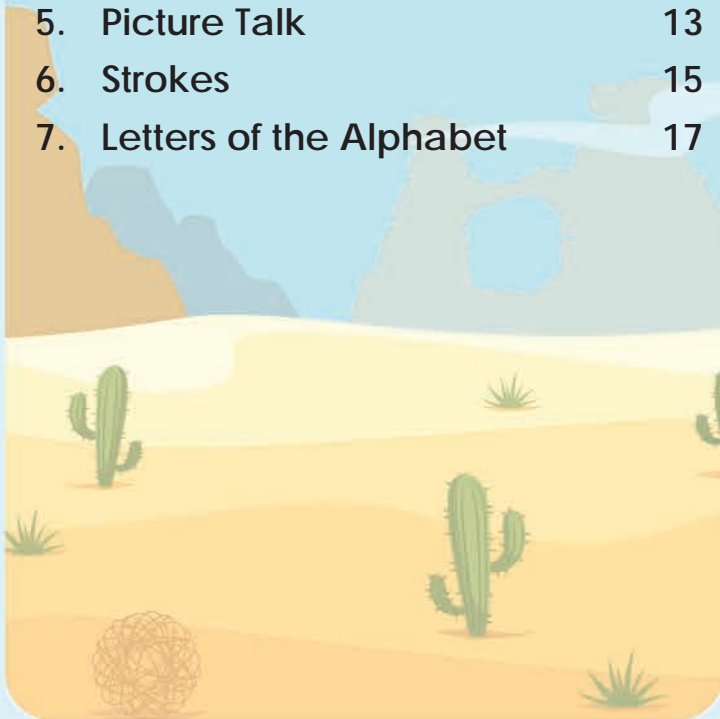

## MATHS



1. Comparing Qualities 21
2. Numbers 33
3. Comparing Quantities 39
4. Shapes 43
5. Sorting and Grouping 47



## EVS



- |                  |    |                  |    |
|------------------|----|------------------|----|
| 1. Myself        | 51 | 7. Cleanliness   | 71 |
| 2. My Family     | 57 | 8. Healthy Food  | 73 |
| 3. My Body       | 61 | 9. Day and Night | 75 |
| 4. My School     | 63 | 10. Good Manners | 77 |
| 5. Places Around | 65 | 11. Water        | 79 |
| 6. My Country    | 67 |                  |    |



# 1. Sounds



## Colour the Bee

Does a bee make a LOUD or a SOFT sound? Colour the bee while you imitate the sound it makes.

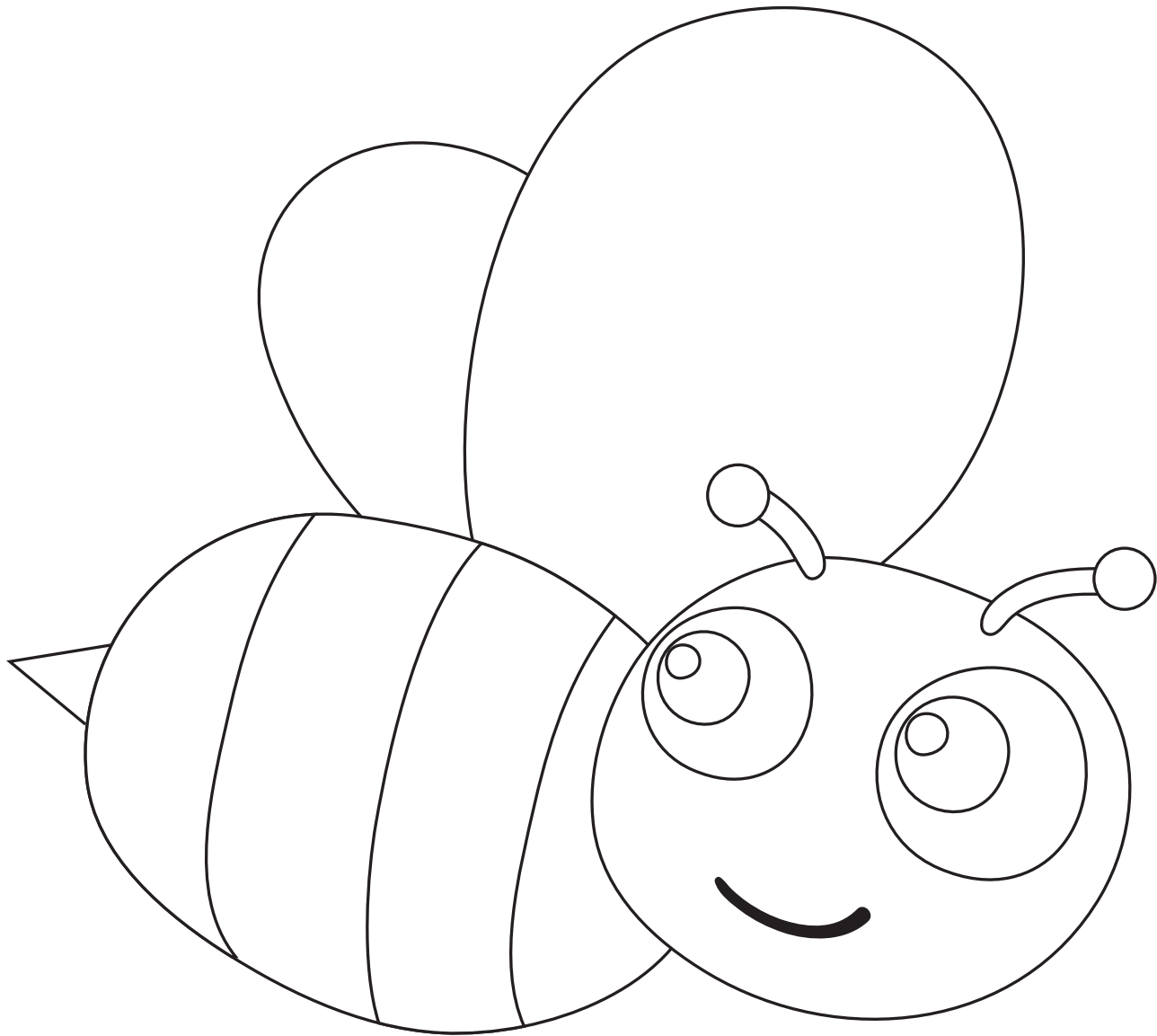



## 2. Talking with Actions and Eyes



### Cut and Paste Gestures

Cut and paste the gestures given on the next page to match them to their words.

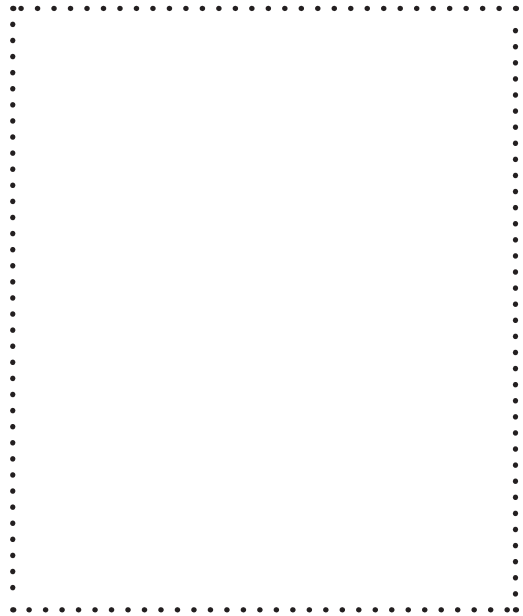

Namaste

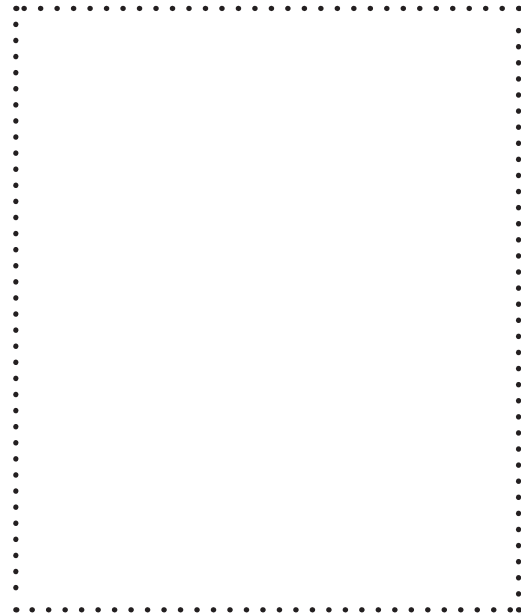

Silence

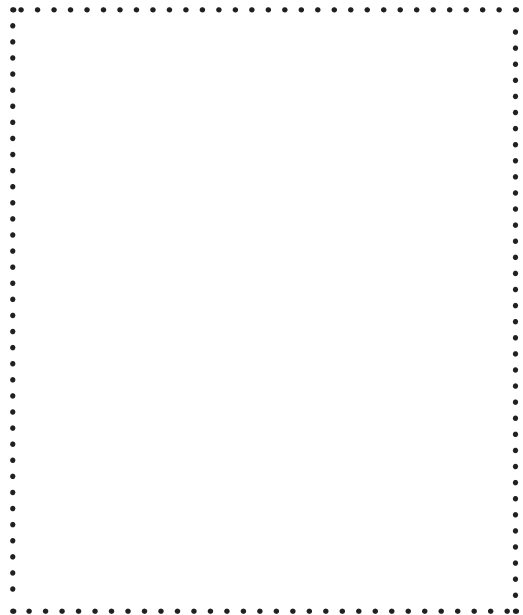

Good Work

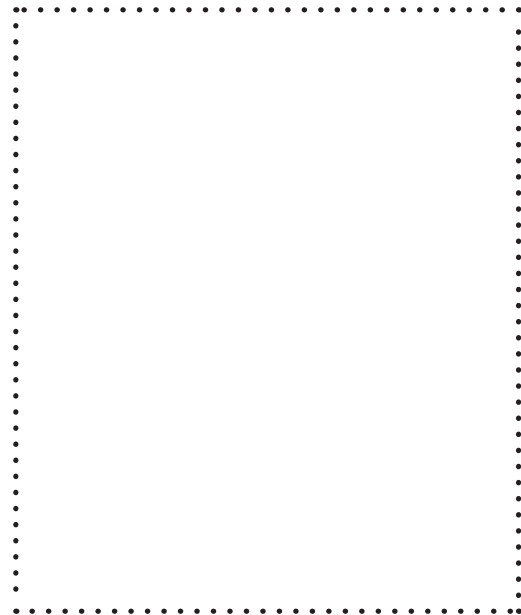

Bye





Cut and paste the gestures given below on the previous page.





### 3. Expressions on My Face



#### Colour and Stick Expressions

Colour the pictures. Then stick the matching pictures of expressions in the circle next to them. Use the sticker page at the end of the book to complete this activity.

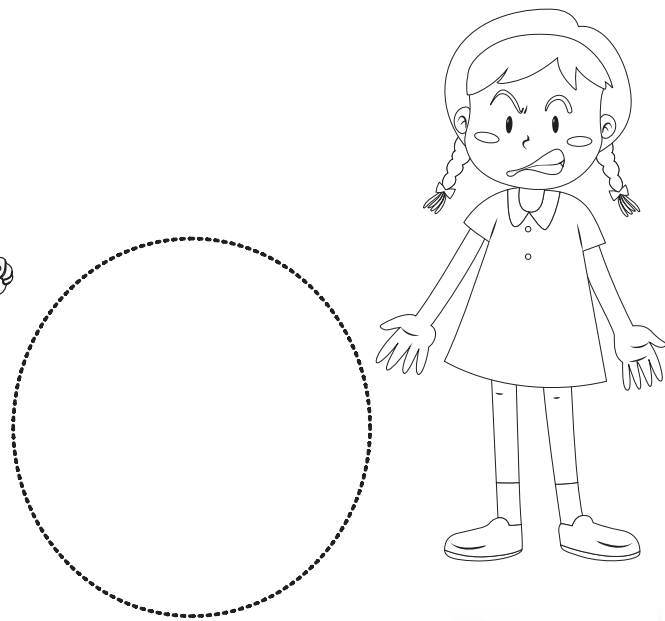
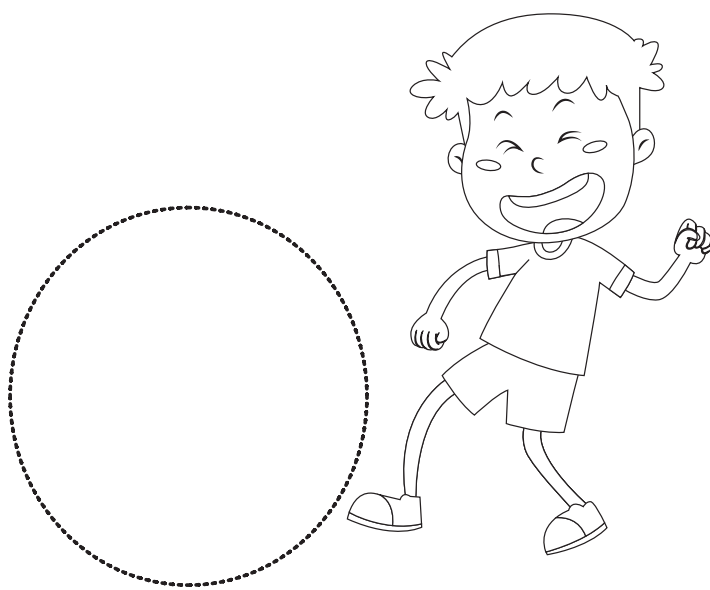
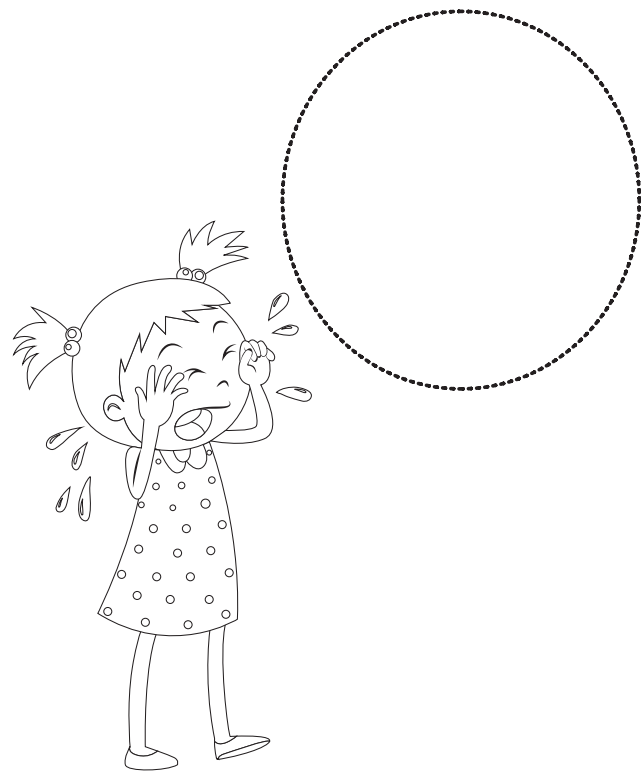
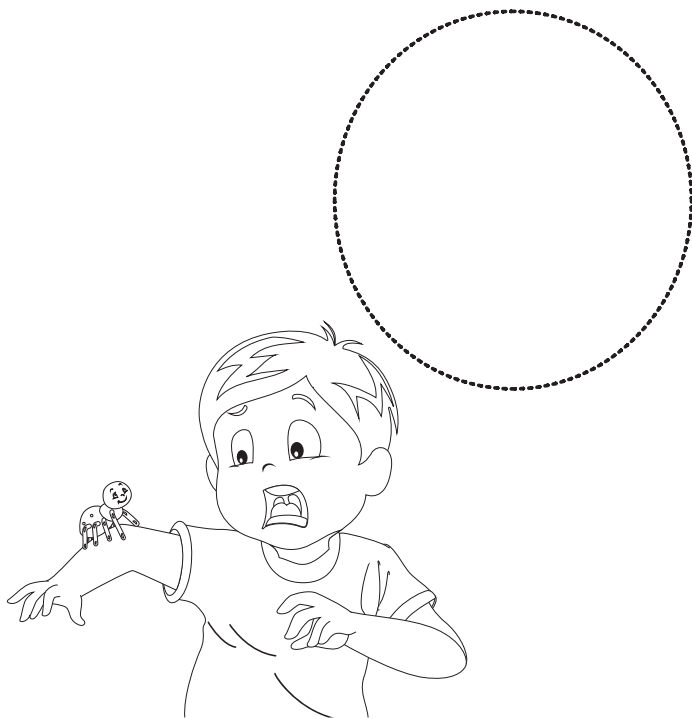



10

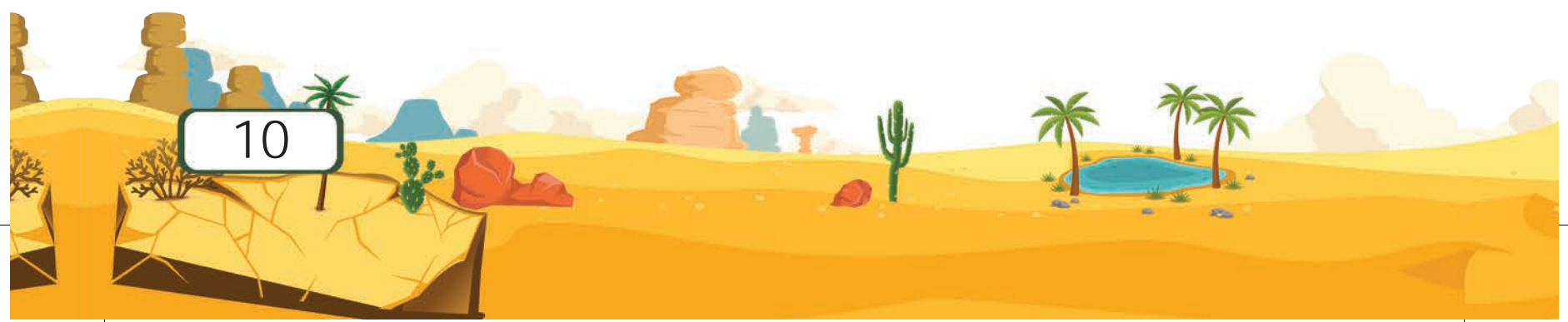

## 4. Spotting Differences



### Spot the Different Object

Spot the object that is different and draw it in the space given below.



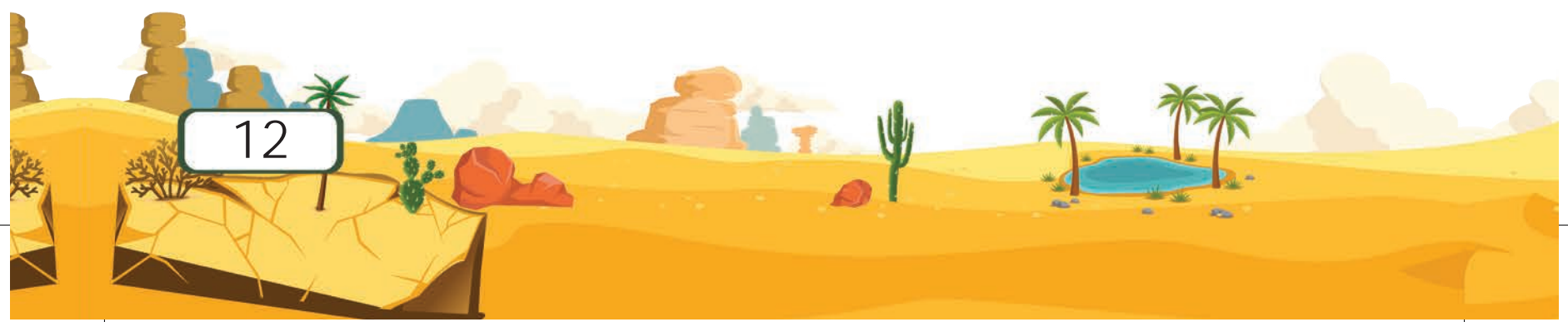
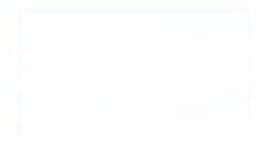

12

## 5. Picture Talk



### A Scene in the Forest

Look at the picture. Colour the fruit that the monkey is eating.

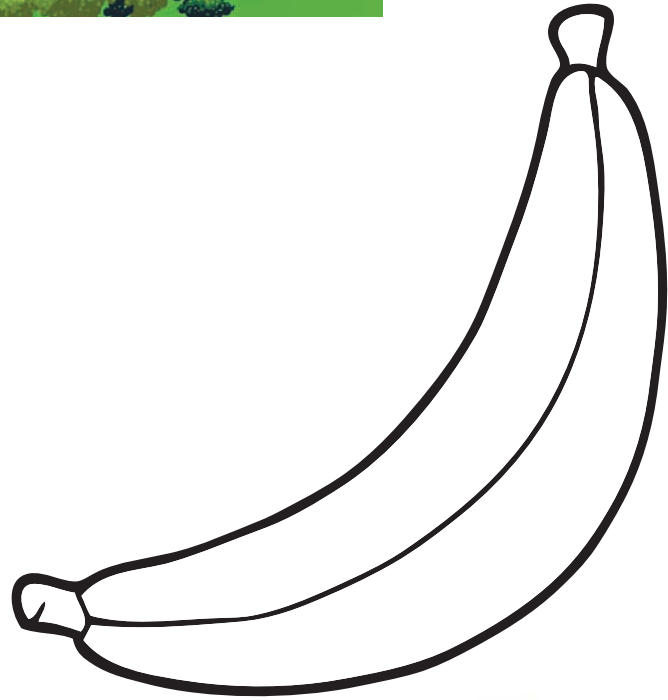
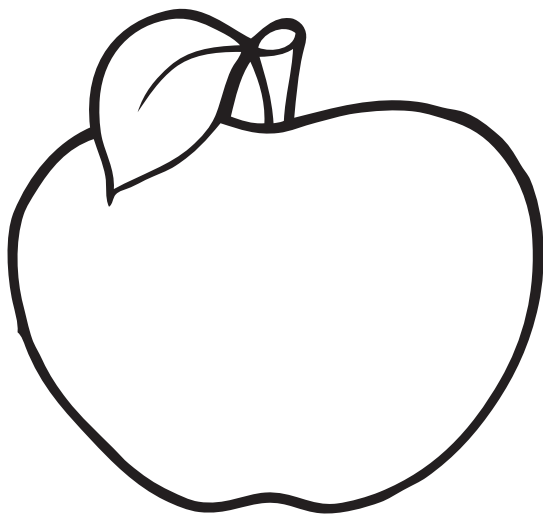



14

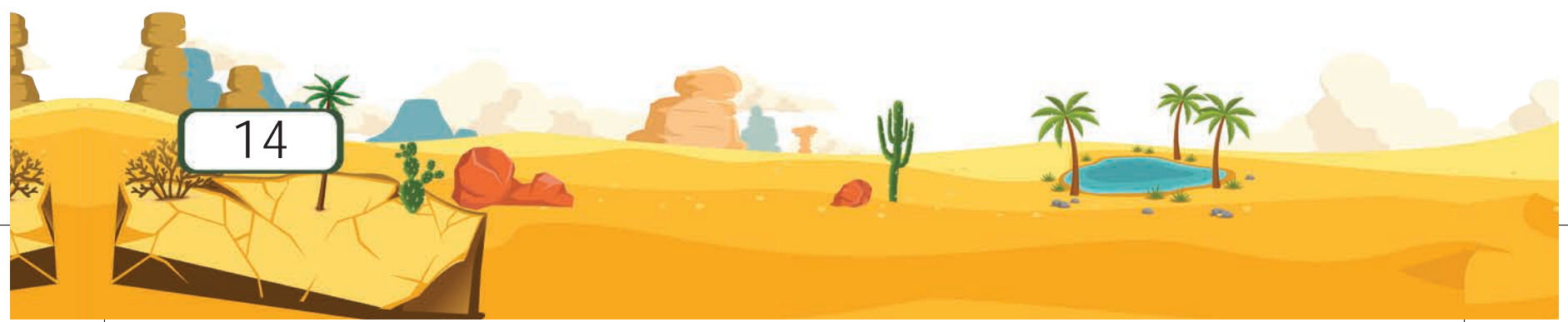

## 6. Strokes



### Trace the Strokes

Trace the lines and curves to complete the house and colour it.

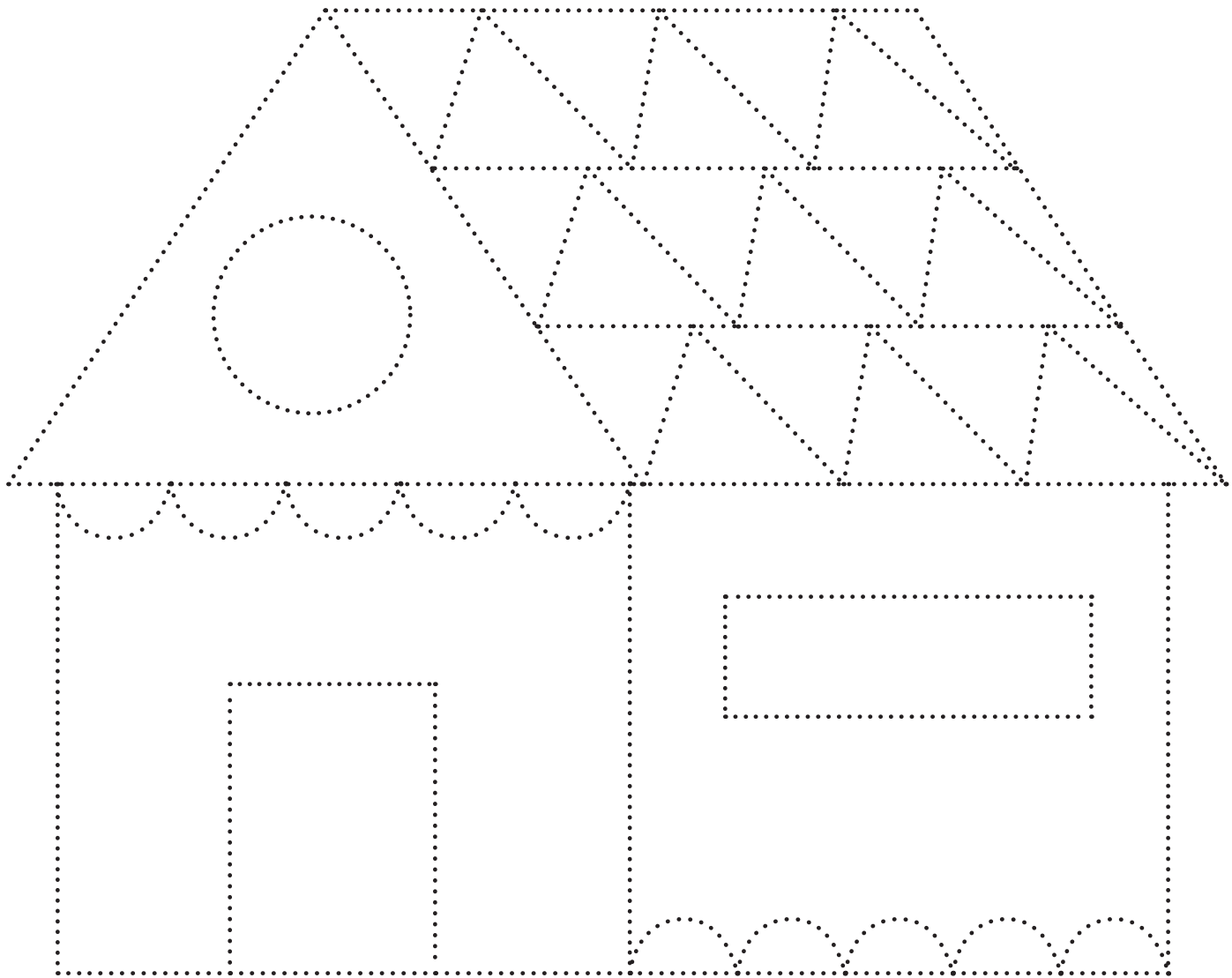

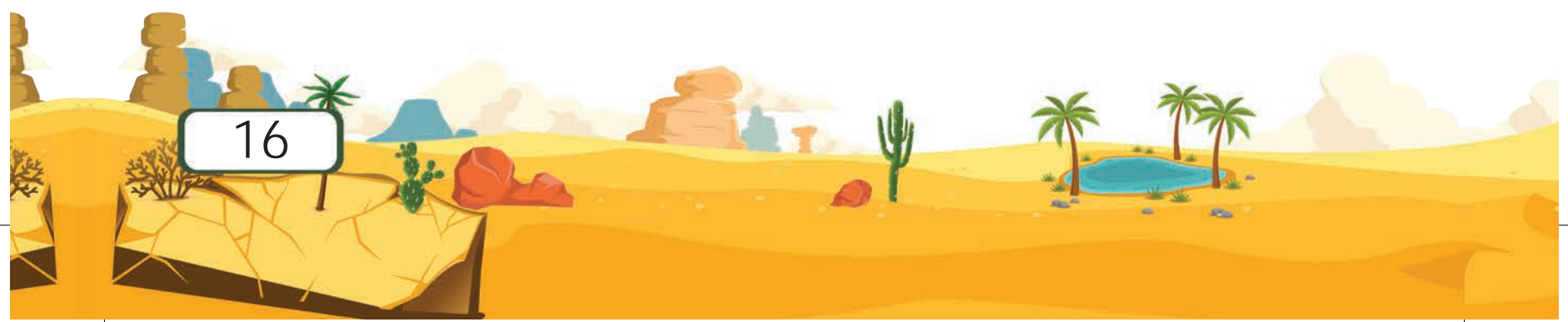

16

# 7. Letters of the Alphabet



## Colour the Pictures

Colour the picture that begins with the letter 'b' in red and the picture that begins with the letter 'm' in yellow.

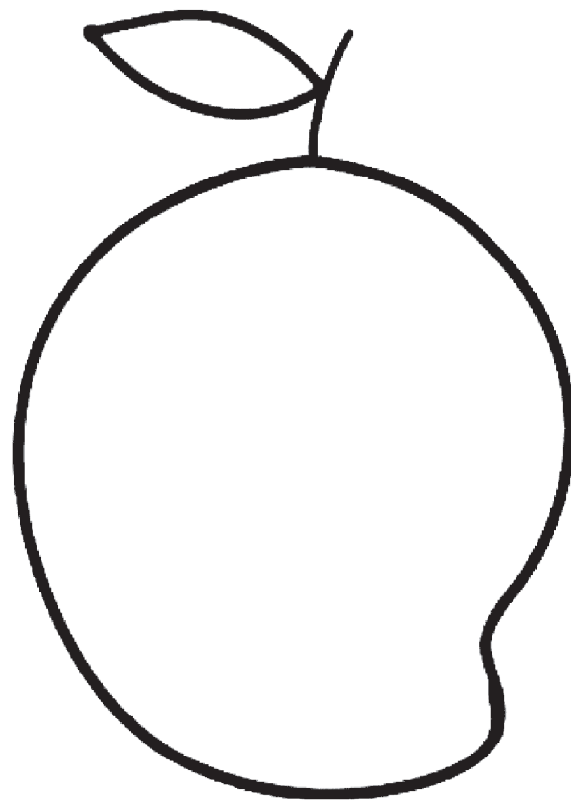
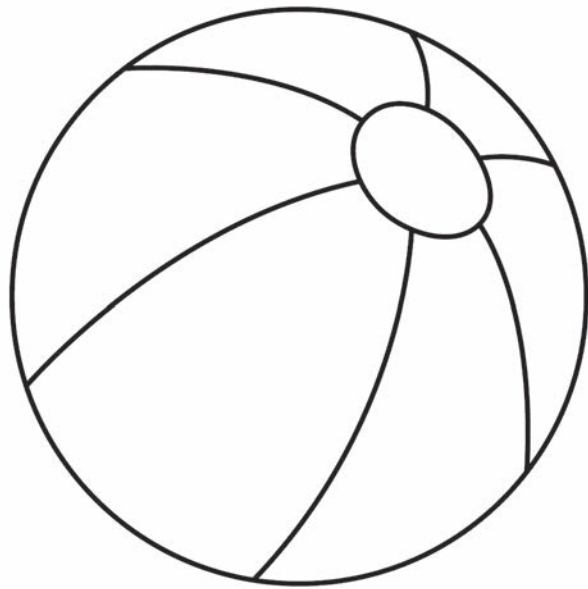

© 2013 COLORINGPAGES.COM

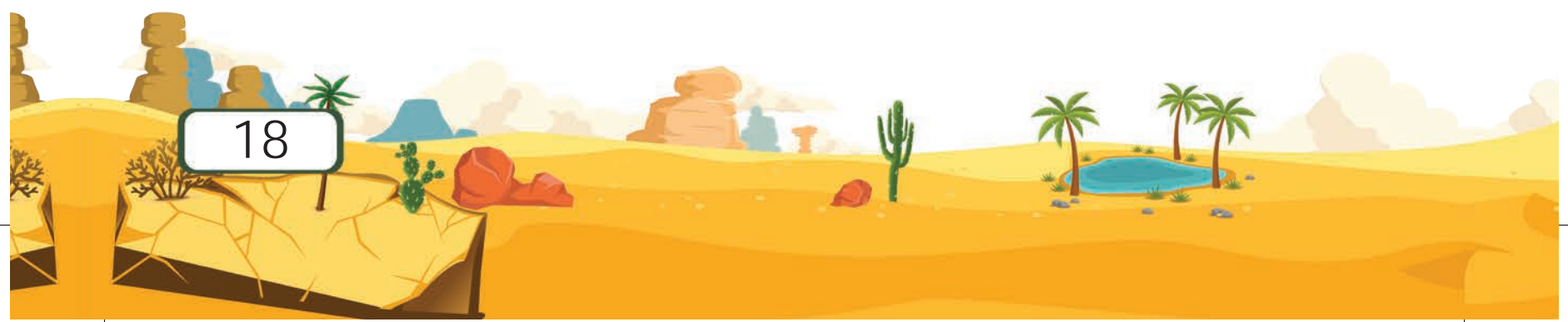

18



## Match Words to Letters

Match the pictures to the beginning letters of their names. Colour the pictures.

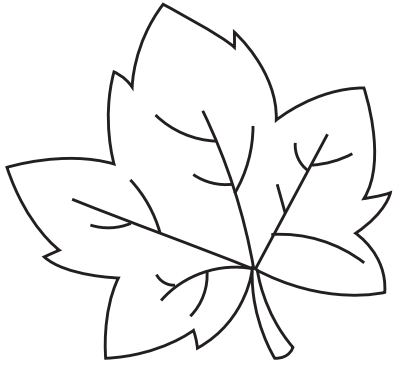

leaf



kettle

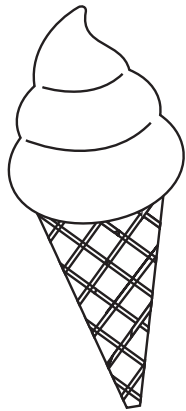

ice cream

i

k

l



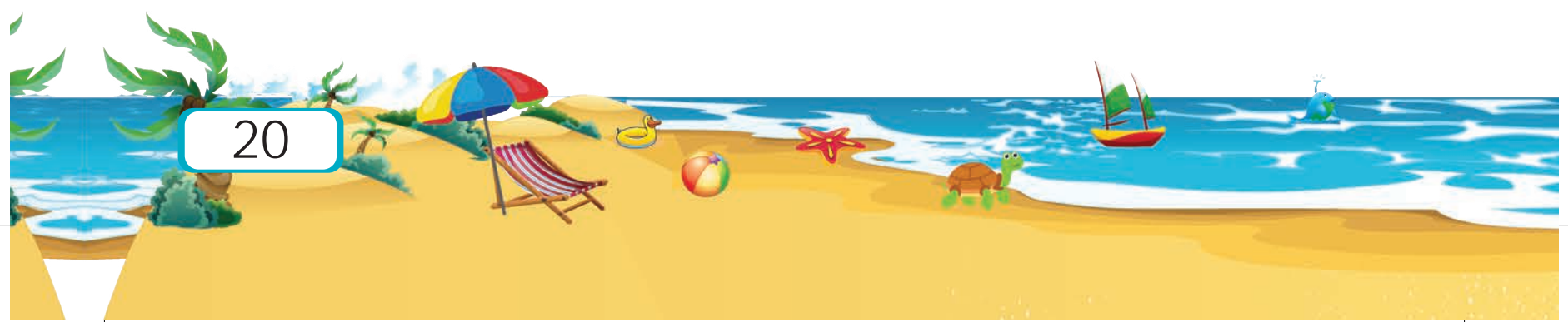



# 1. Comparing Qualities



## Colour Big and Small Balloons

With finger paint, make blue colour thumb prints on the BIG balloons. Make red colour thumb prints on the SMALL balloons.

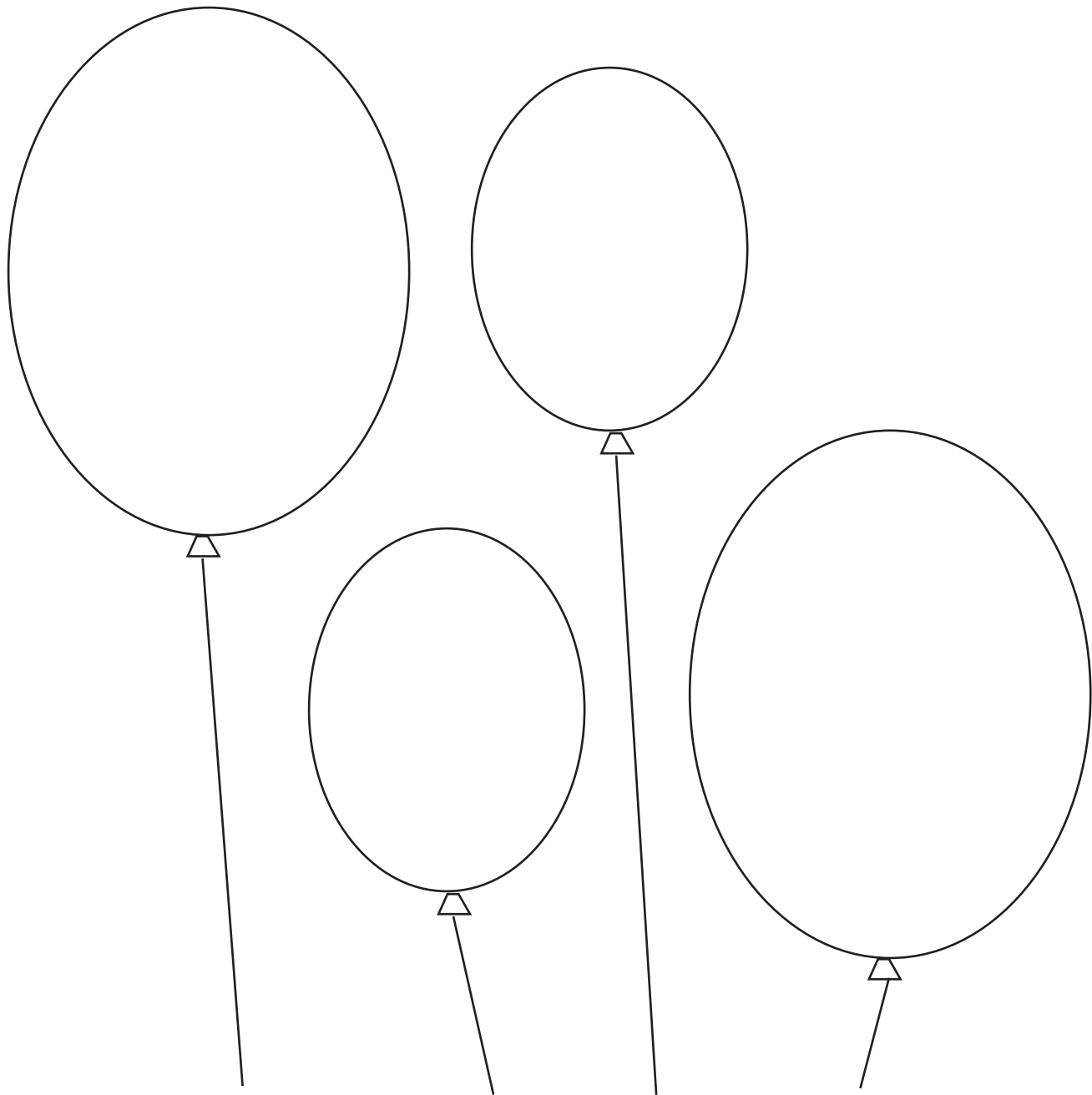

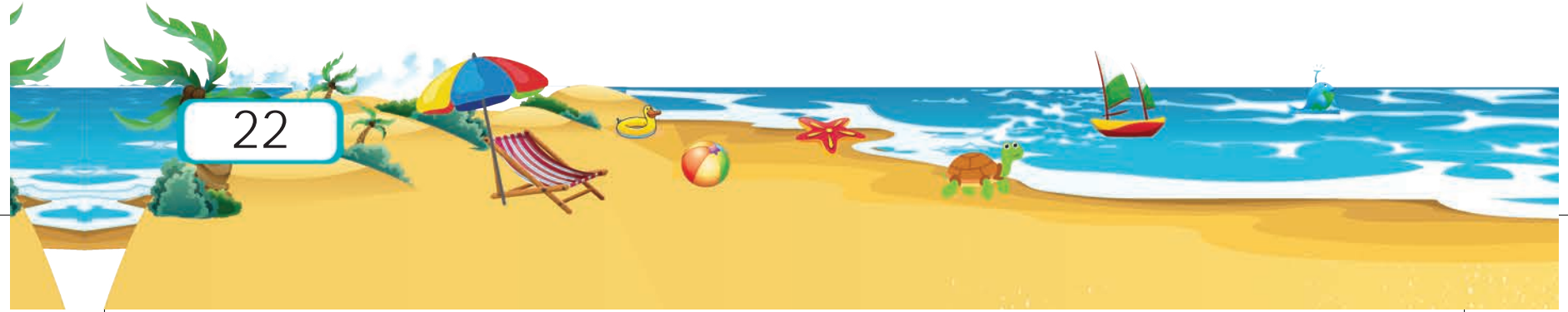



## Colour the Glass Full

Colour one of the glasses with orange colour to make it FULL of orange juice. Then, write 'F' for the glass that is FULL and 'E' for the glass that is EMPTY.

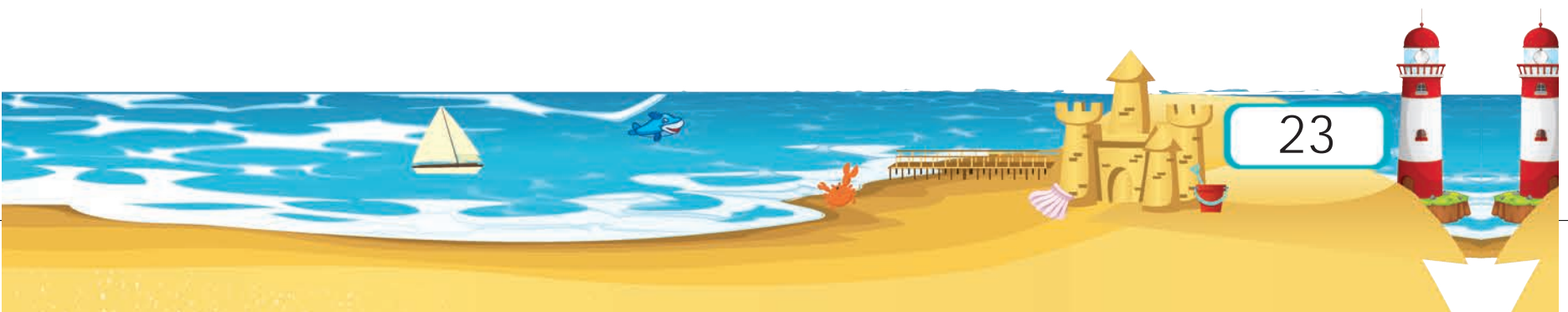
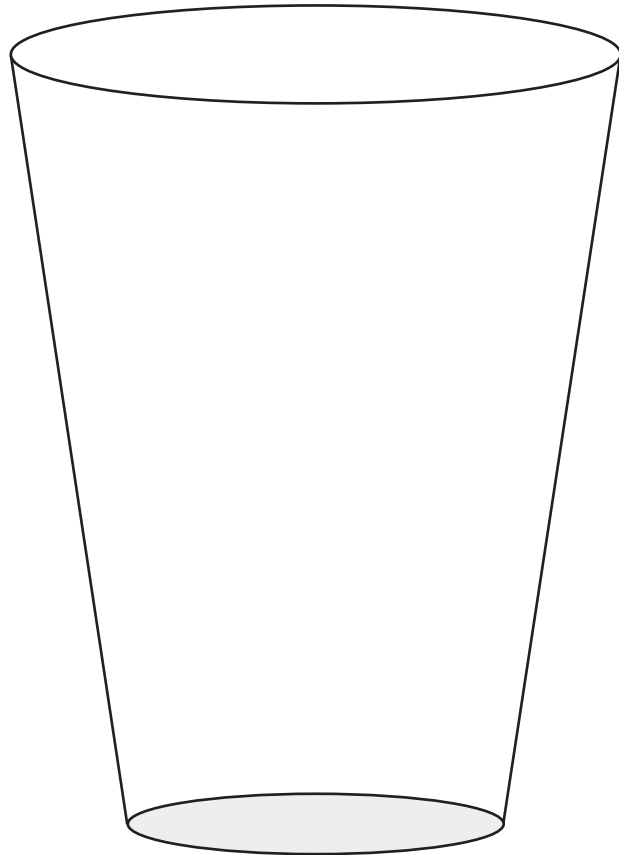
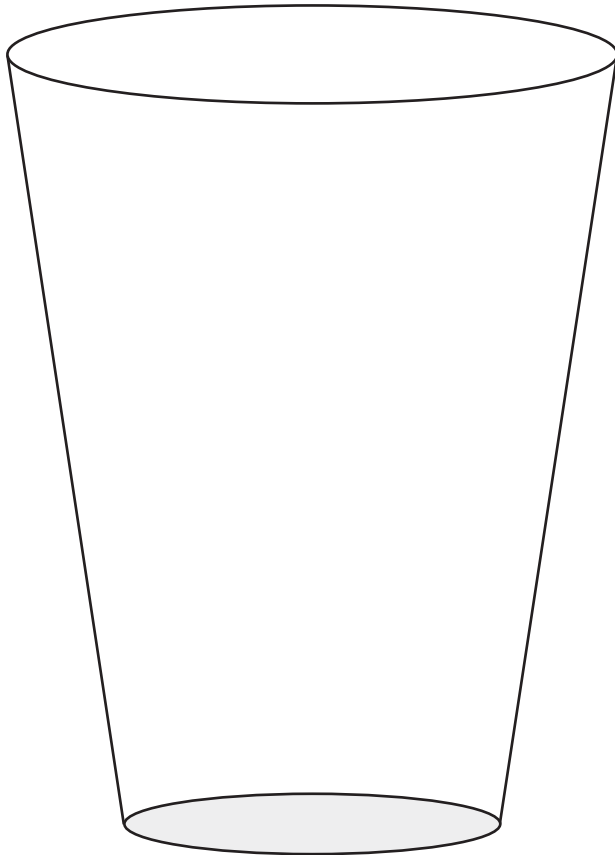

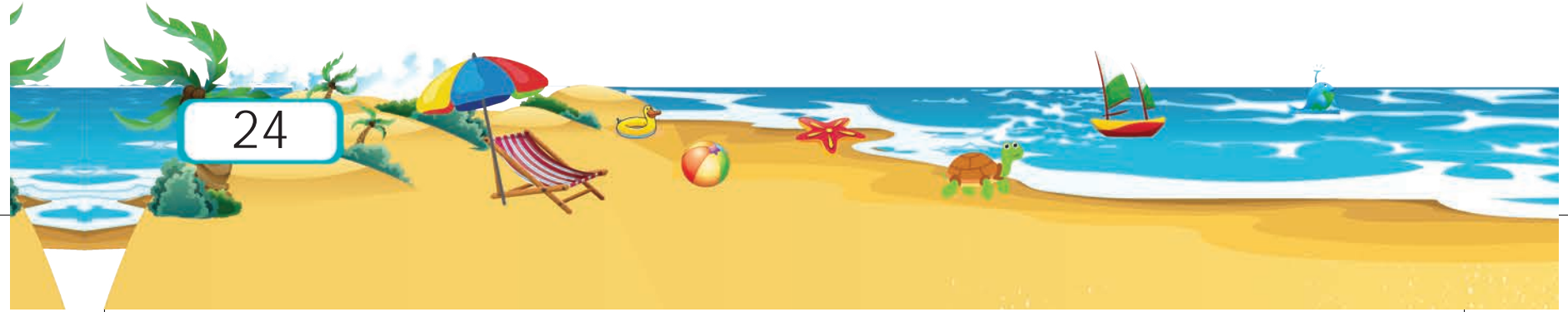



## Colour Thick and Thin Objects

Colour the THICK objects in yellow and the THIN objects in green.

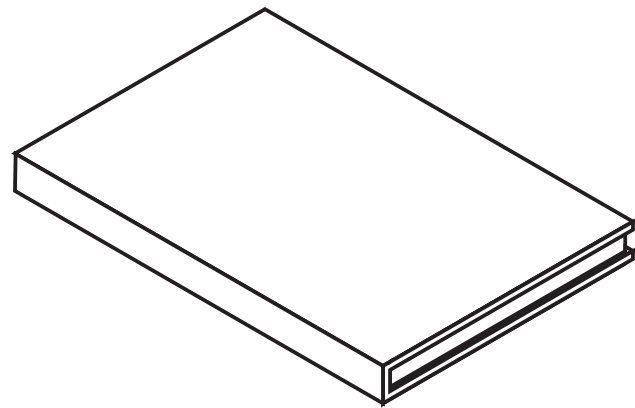
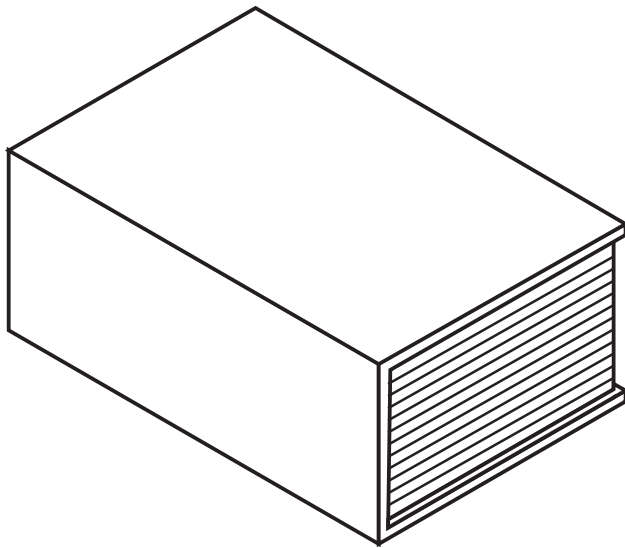

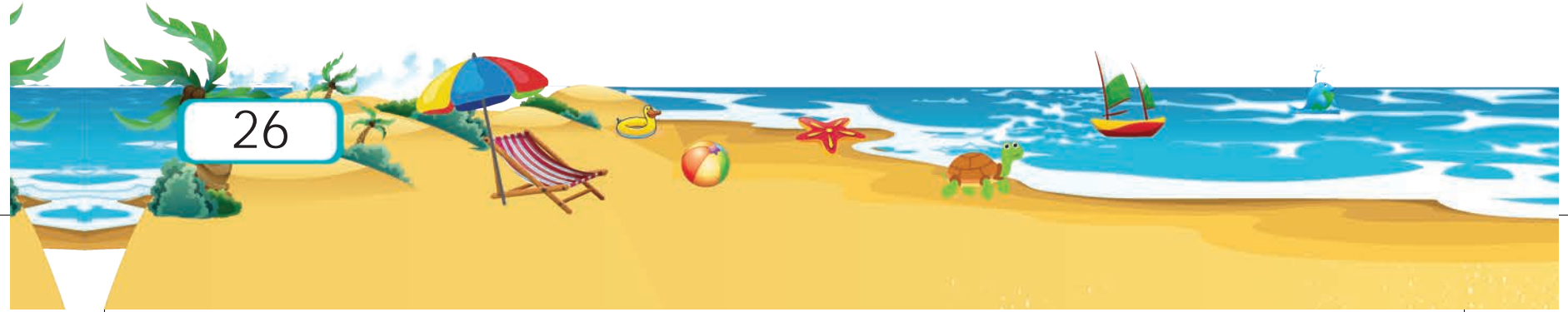
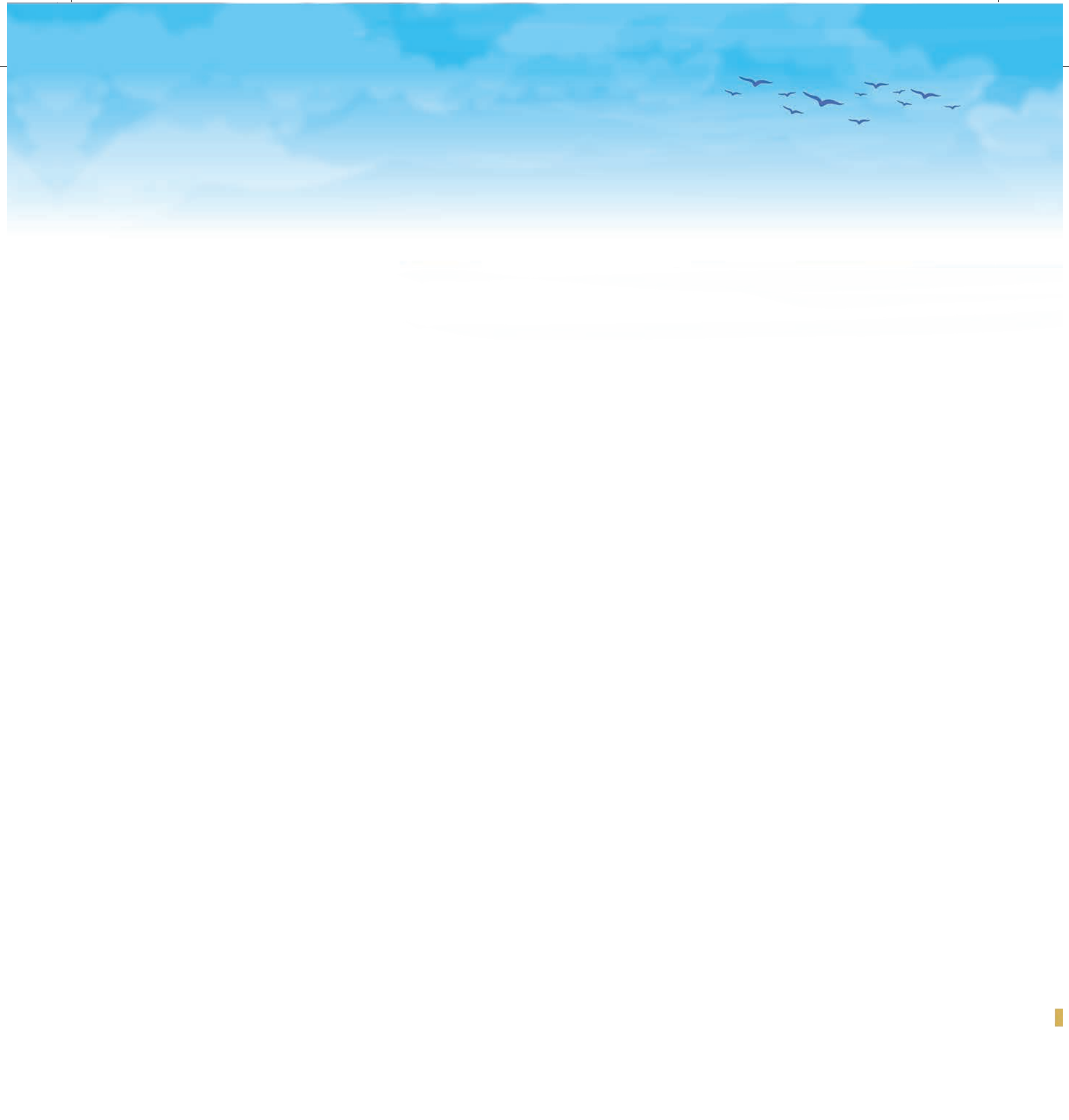

26



# Trace the Tall Ladder

Here is a SHORT ladder. Can you trace the TALL ladder?



The activity shows two ladders on a brown ground line. On the left is a short ladder with two vertical brown posts and four horizontal brown rungs. On the right is a tall ladder made of dashed lines, consisting of two vertical posts and ten horizontal rungs. The background features stylized green buildings and trees.



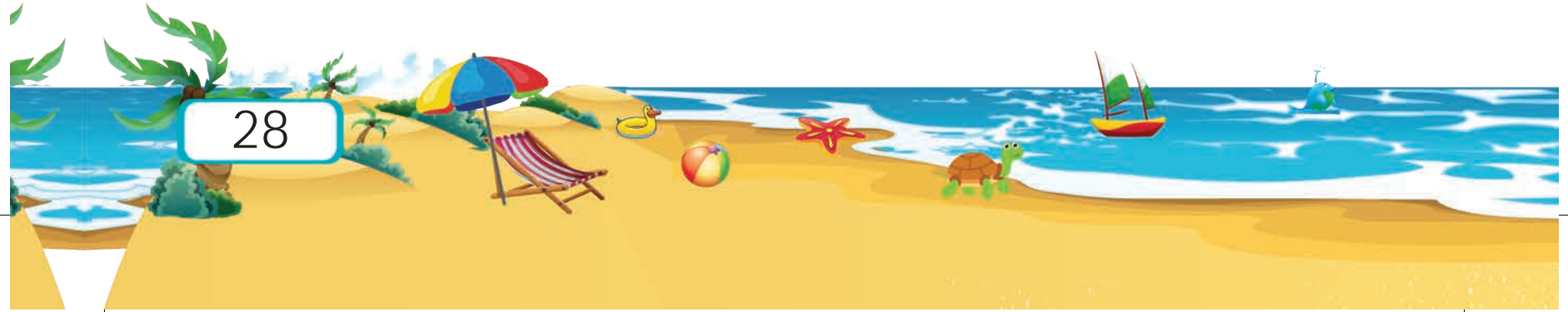



## Colour the Child

Colour the child holding the SHORT rope.



Ram

Ana

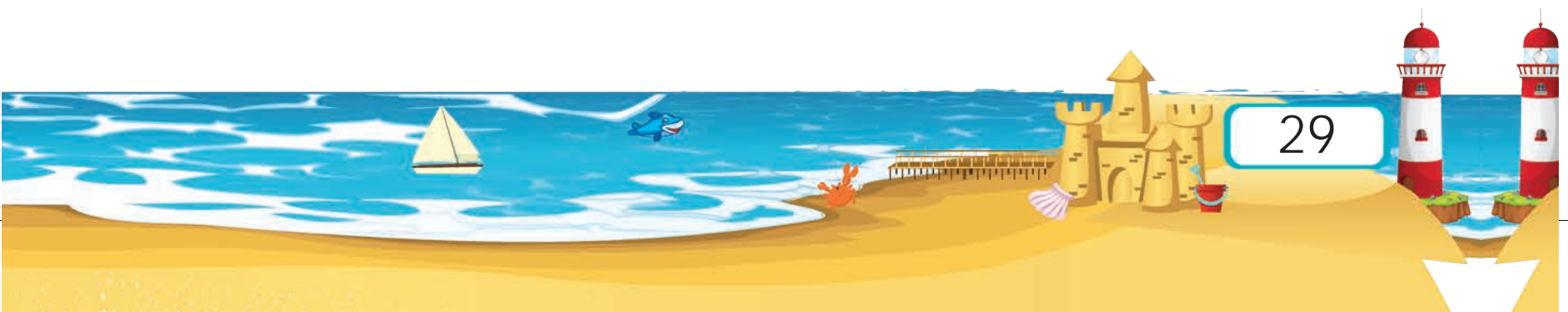



30



## Draw and Colour Light Objects

Look at the objects in each of the pairs given below.  
Draw and colour the LIGHT object in the space given.

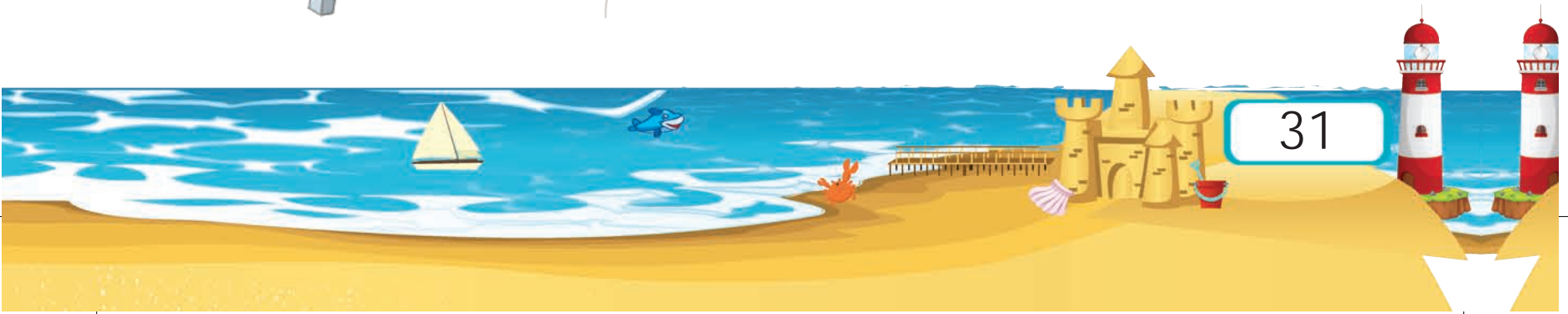
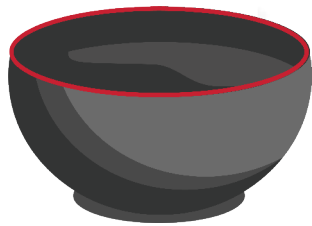

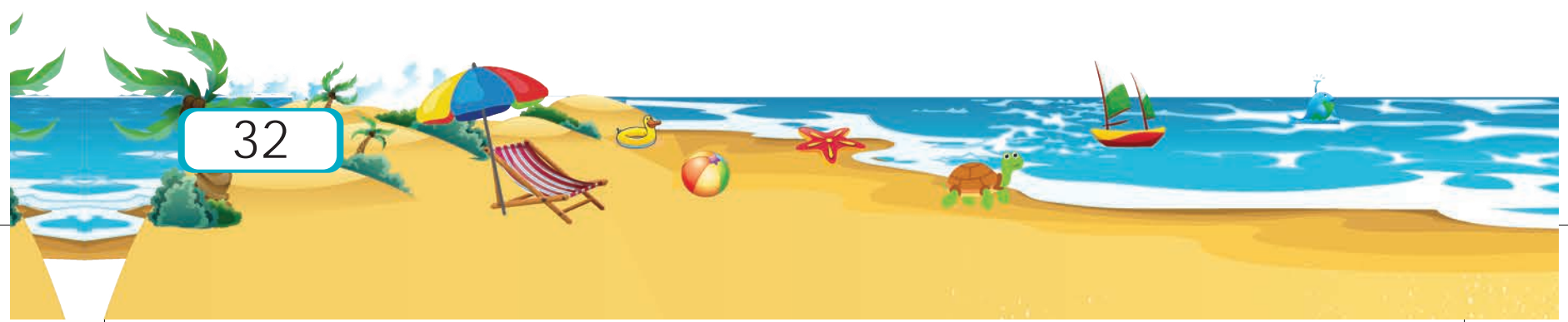

## 2. Numbers



### Colourful Number Caterpillar

Dip a water bottle cap in paint and make 10 circles in various colours to make the number caterpillar. Then write 1 to 10 in the circles.

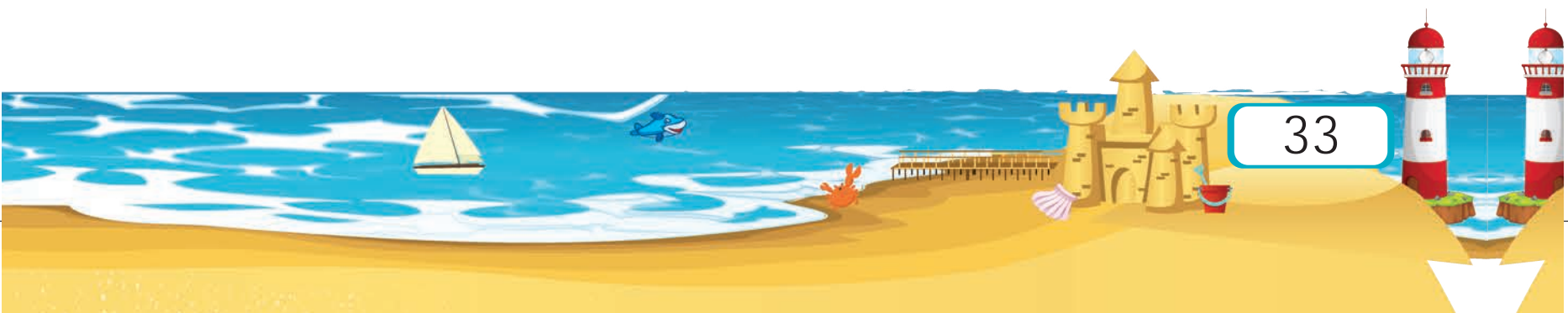
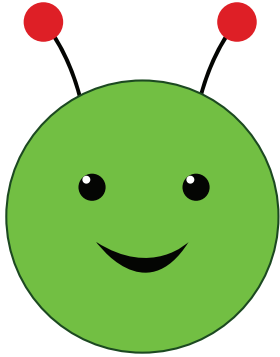





## Missing Numbers 21 to 50

Write the missing numbers in the ladder.

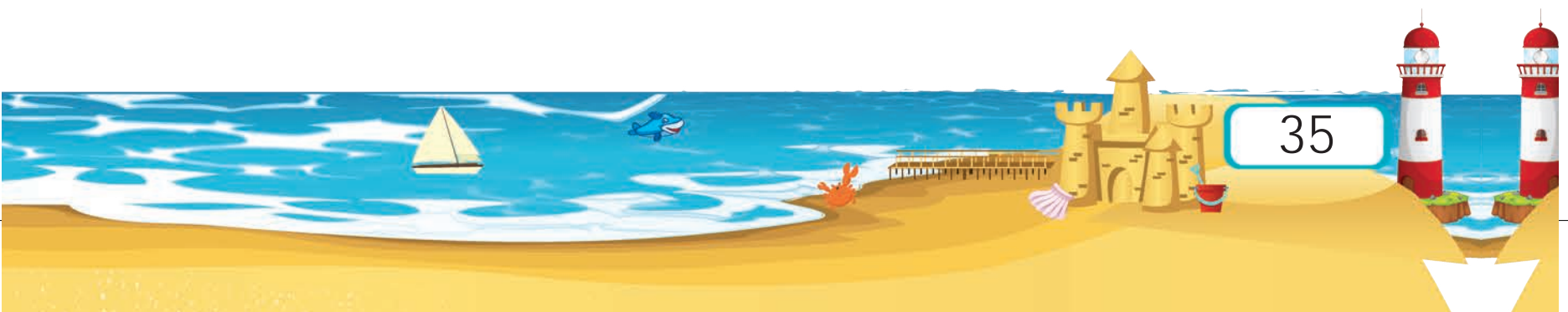
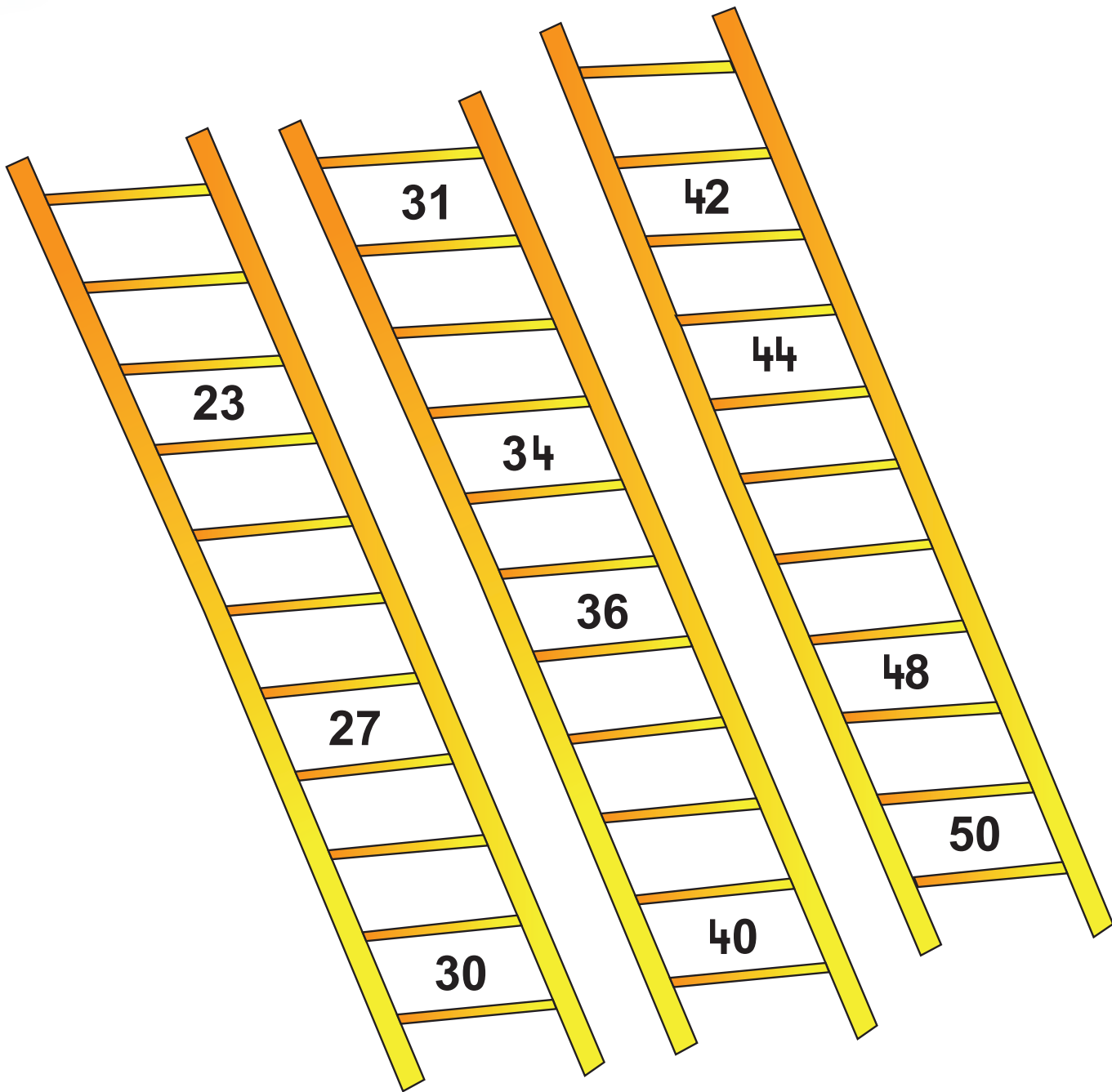

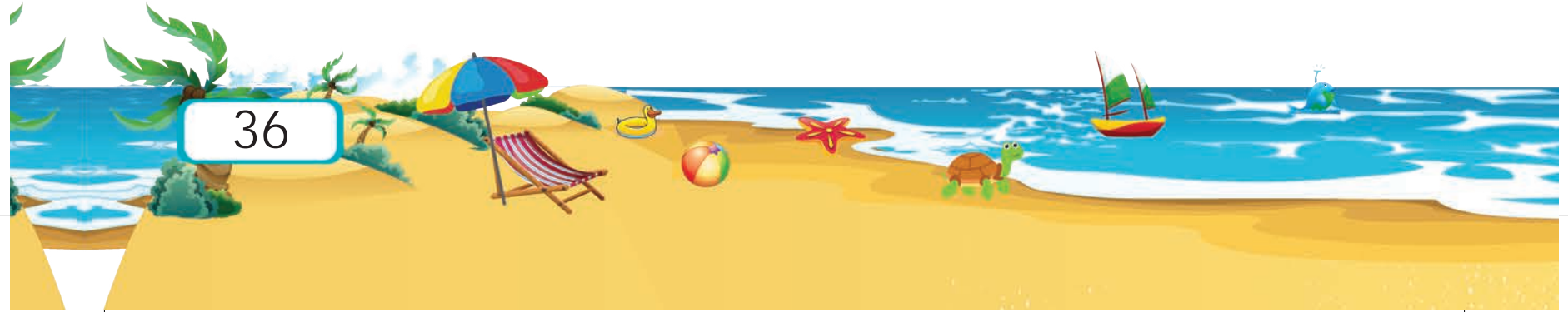



## Draw and Colour

Draw fruits in the basket that has ZERO vegetables or fruits in it.

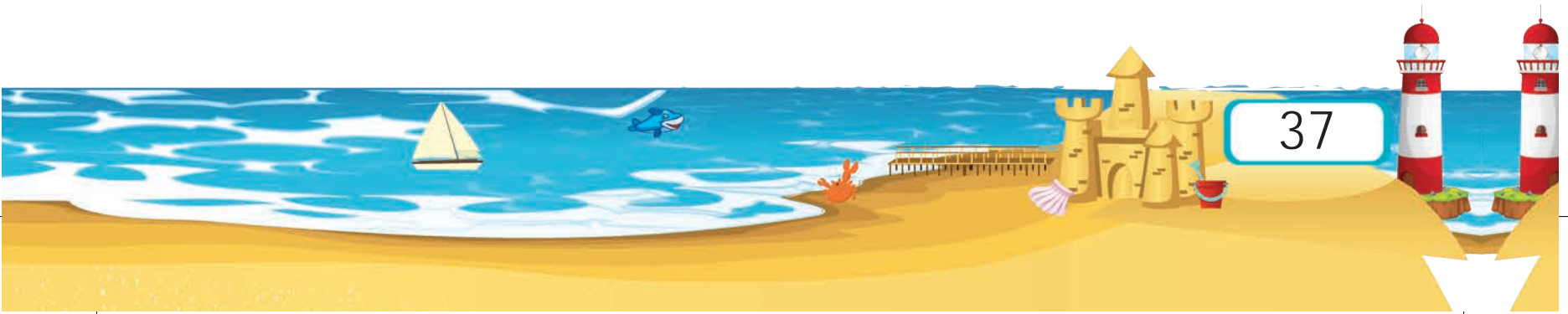
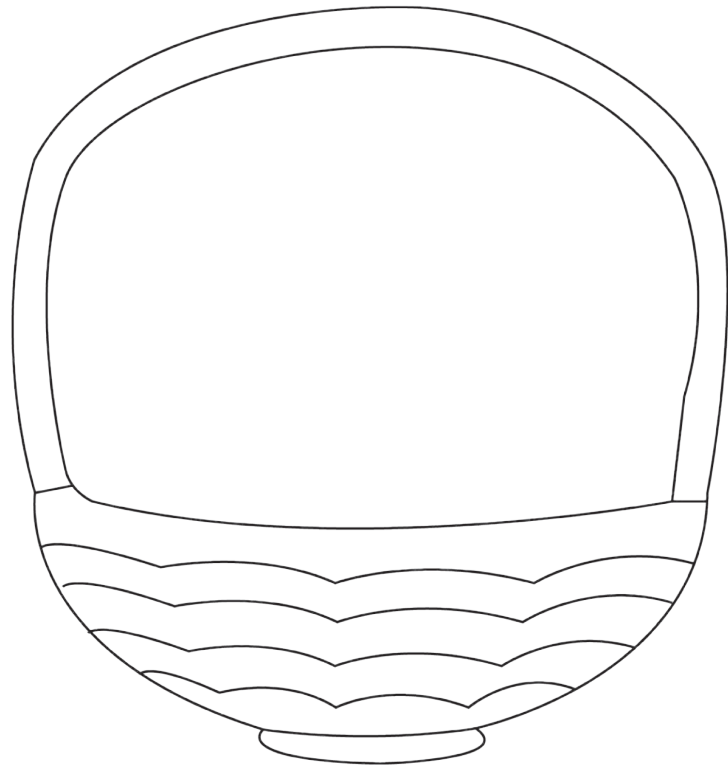



### 3. Comparing Quantities



#### Colour the Set with Less Numbers

Strike(/) the objects in the set that has MORE number of objects. Colour the objects in the set that has LESS number of objects.

#### Set 1

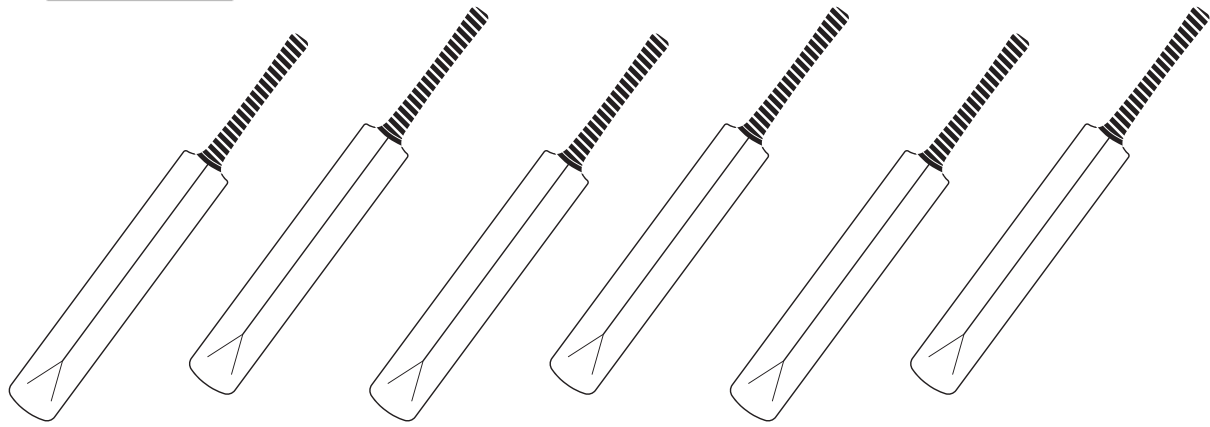

#### Set 2

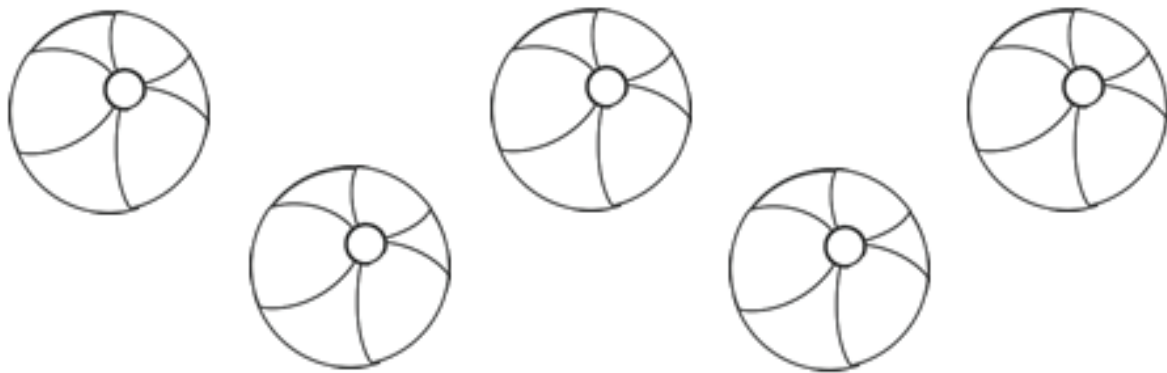

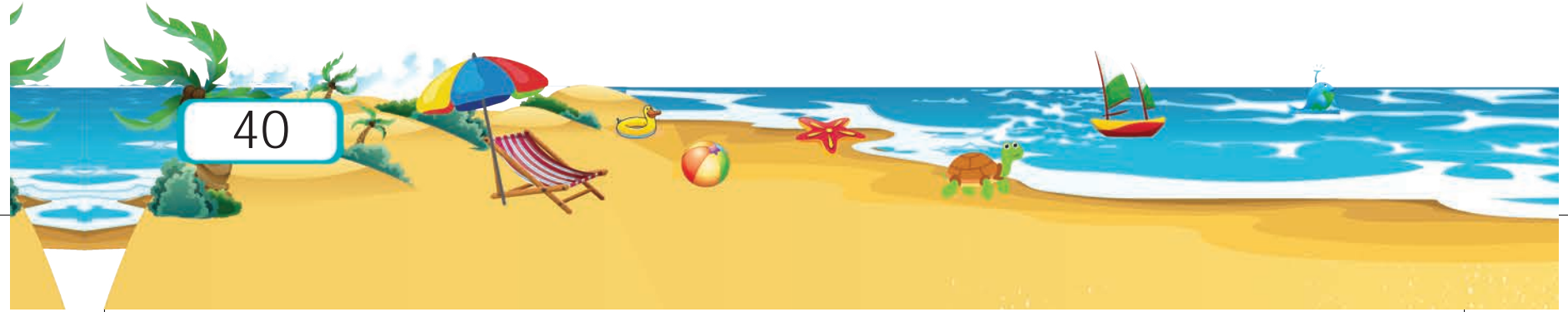

40



## Thumb Print Equal Numbers

Count the objects in each box. Make EQUAL number of thumb prints on the other side in the empty box.

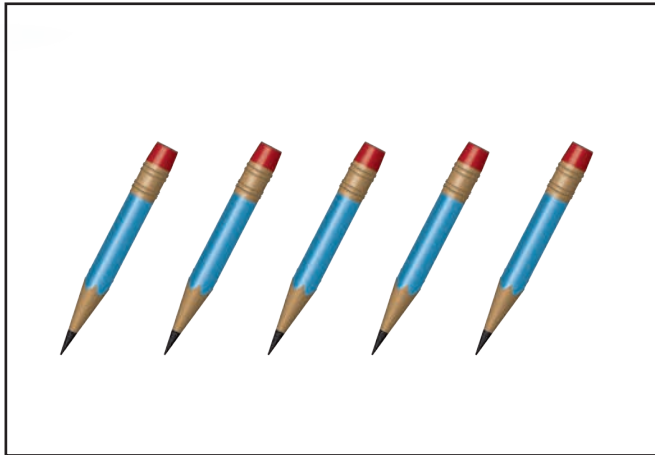
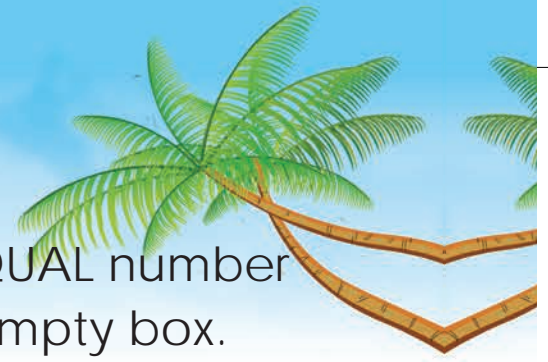

=

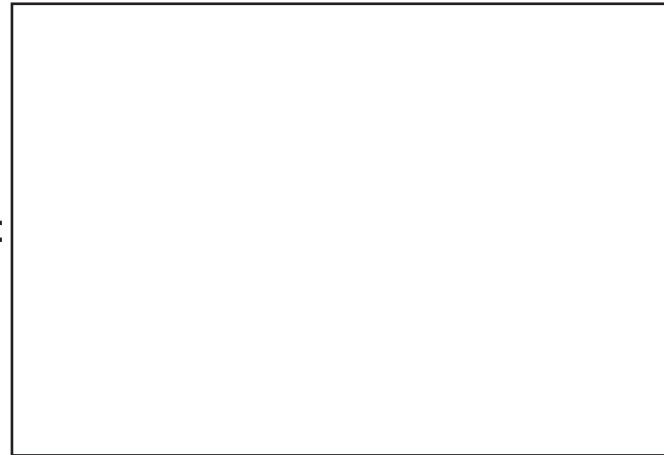

=

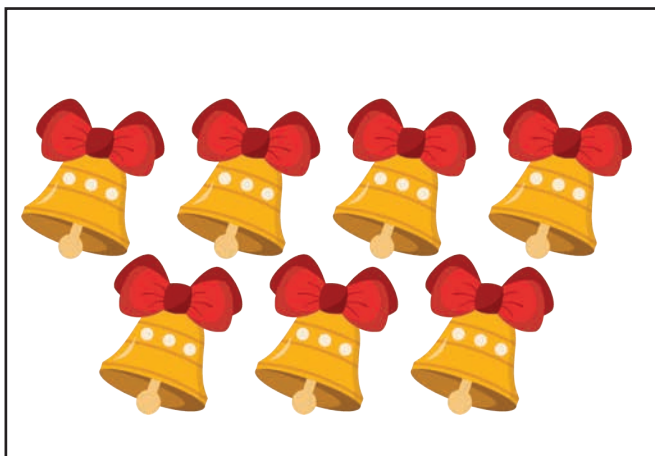

=



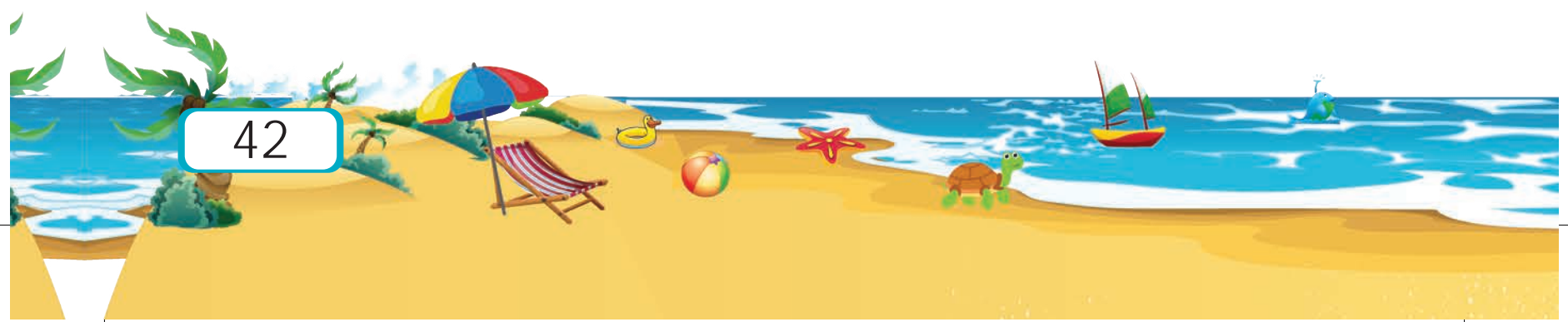

# 4. Shapes



## Colour and Sort by Shape

Colour the shapes at the bottom of the page. Cut along the dotted lines and paste in the correct boxes.

Circle

Square

Triangle

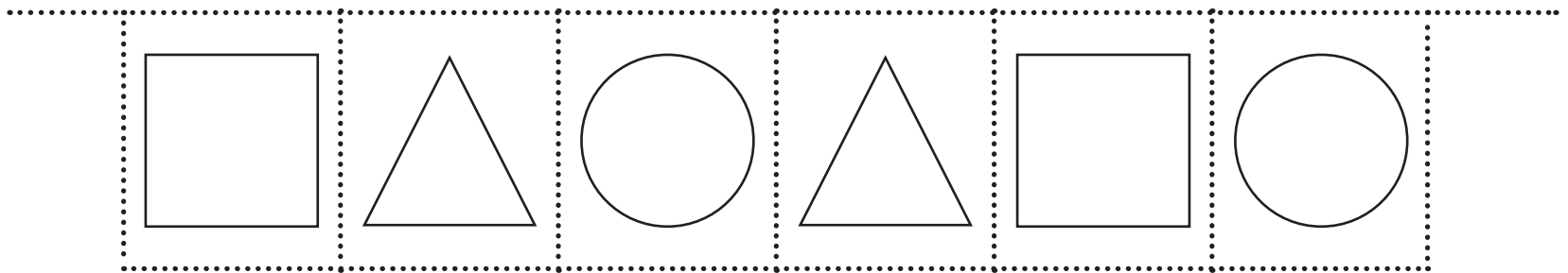





# Complete the Robot

Trace the RECTANGLES to complete the robot.

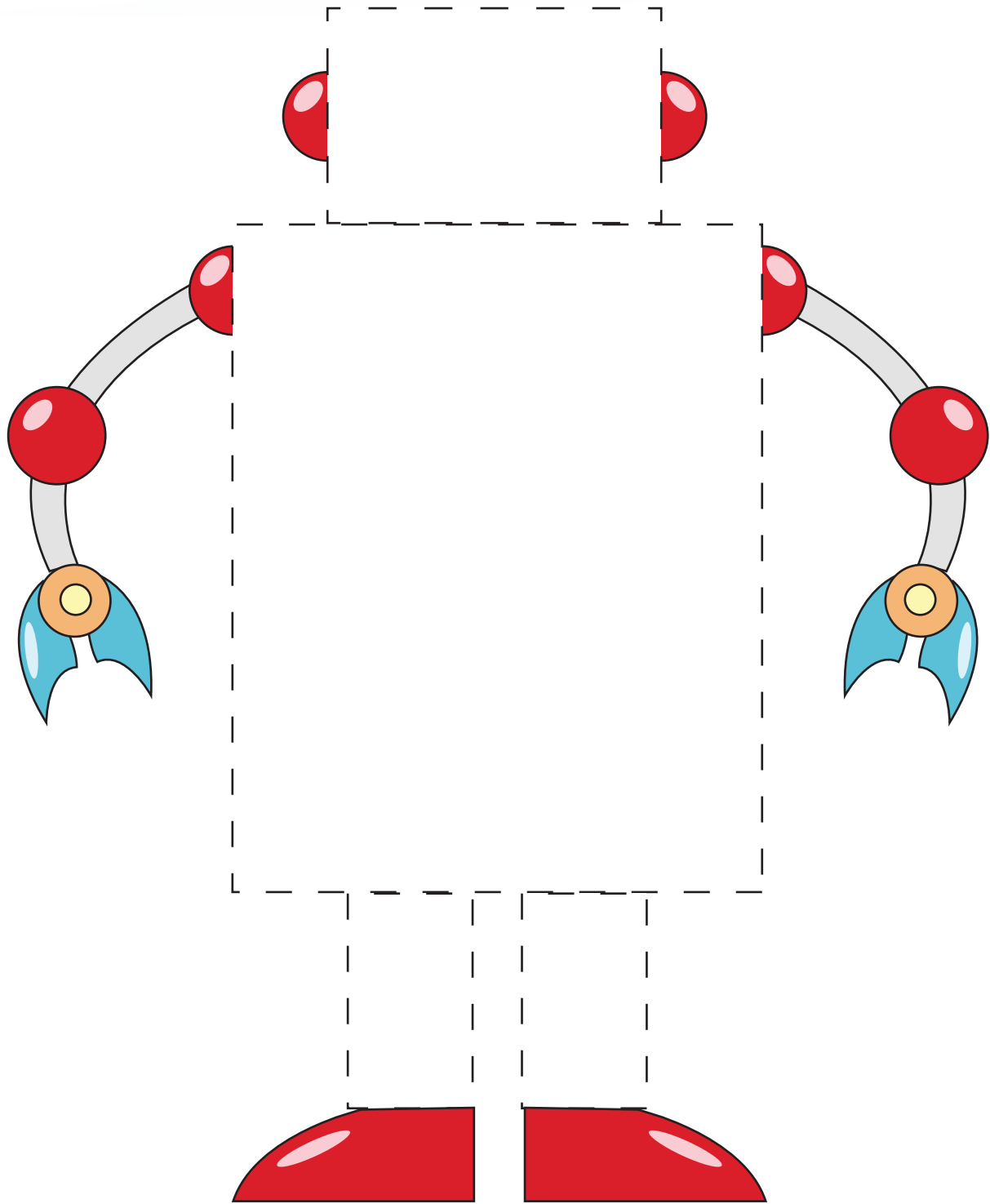



46

# 5. Sorting and Grouping



## Trace and Colour

Trace and complete the pictures. Paint the fruits that are yellow in colour with your finger.

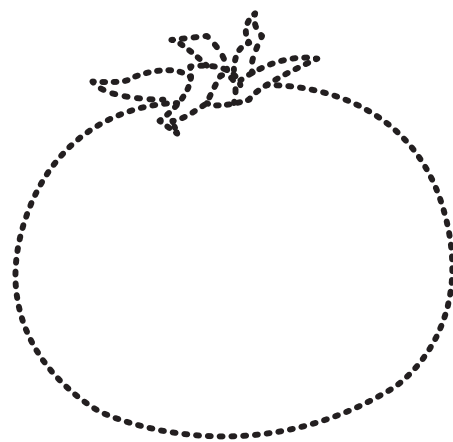
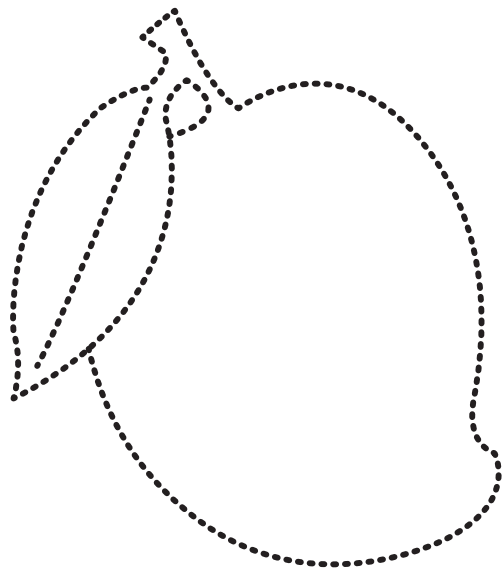
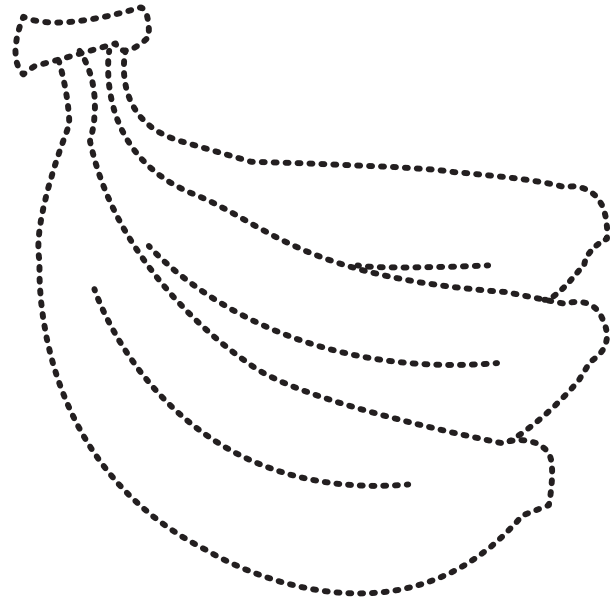
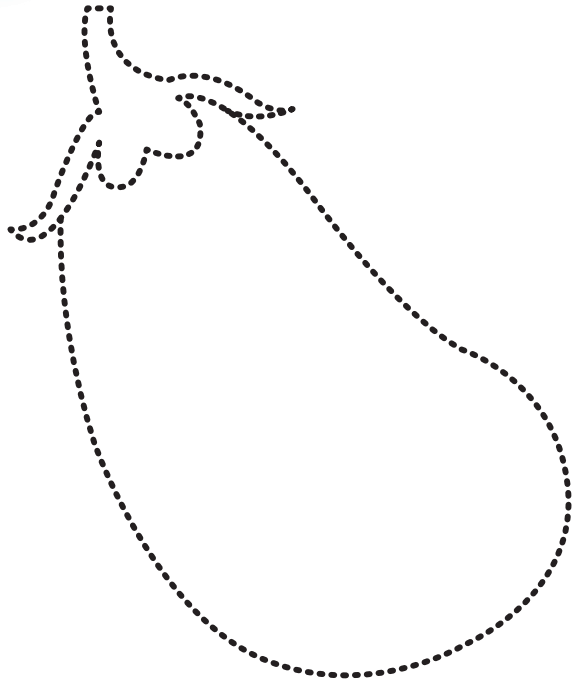

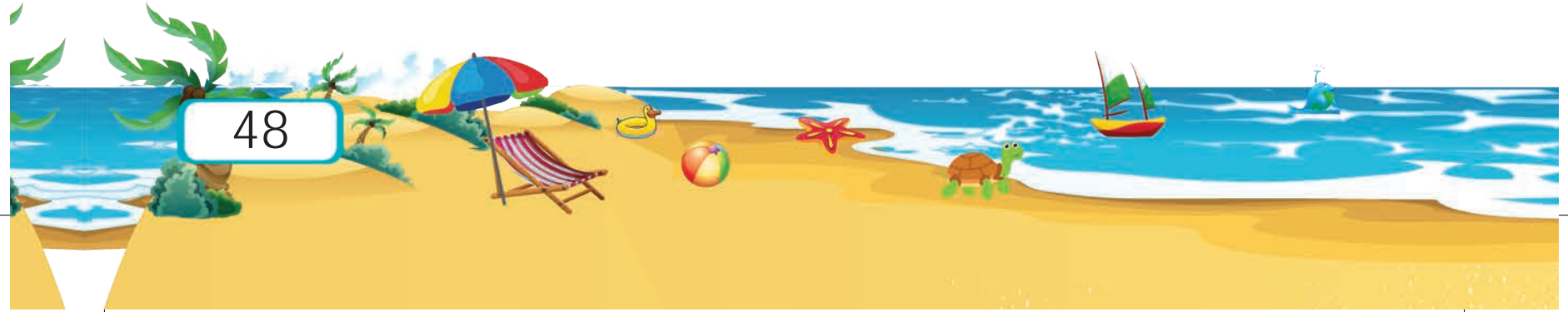





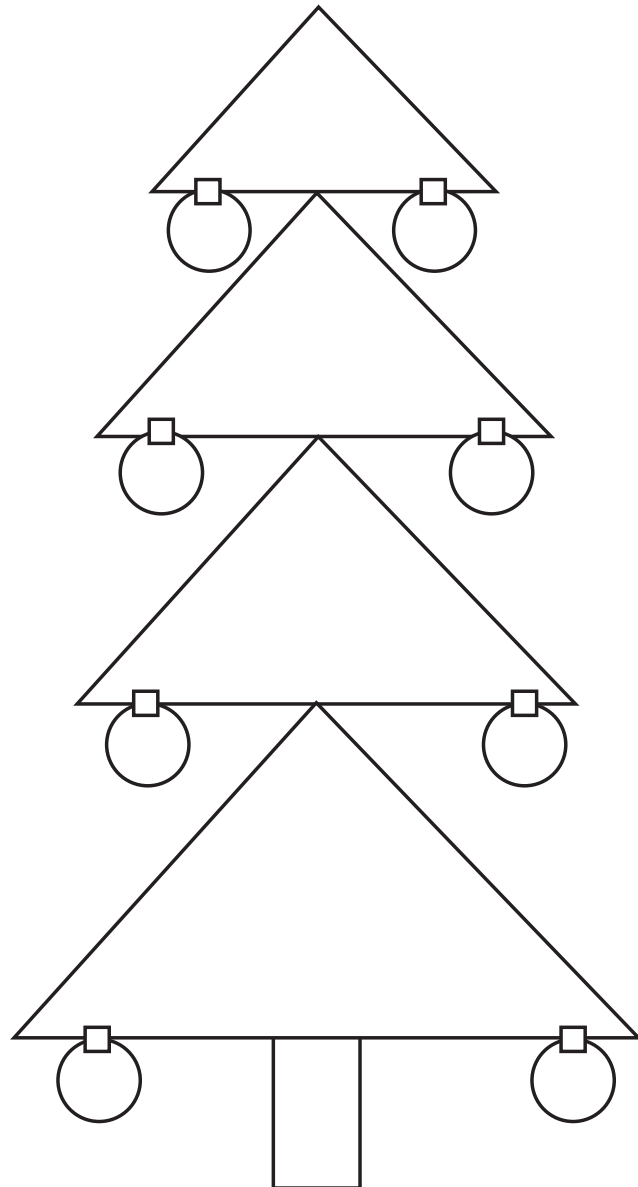
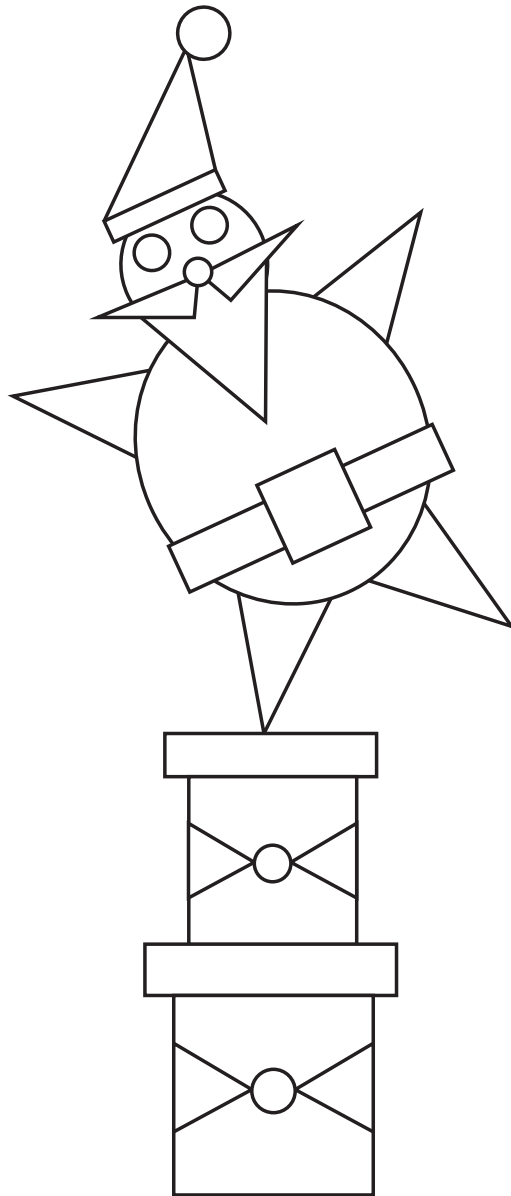

## Find Shapes and Colour

How many SQUARES, TRIANGLES, RECTANGLES AND CIRCLES can you see in the picture? Count and write in the boxes given. Then colour the picture according to the colour code.



<input type="checkbox"/>	<input type="checkbox"/>	<input type="checkbox"/>	<input type="checkbox"/>
Square	Triangle	Rectangle	Circle
			

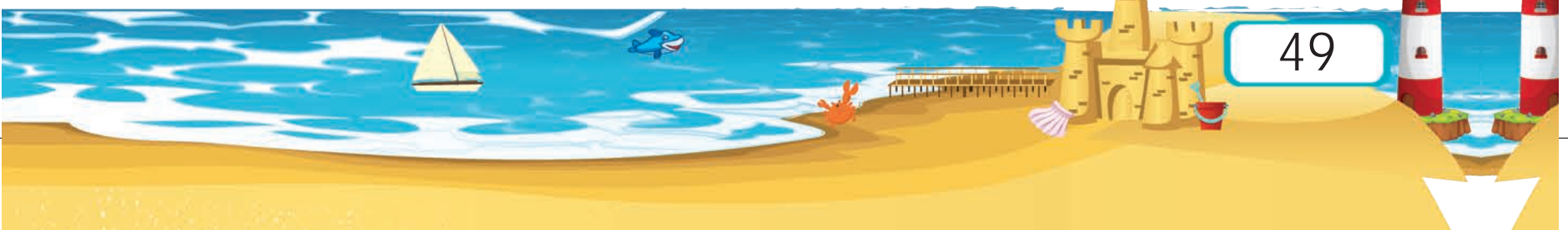

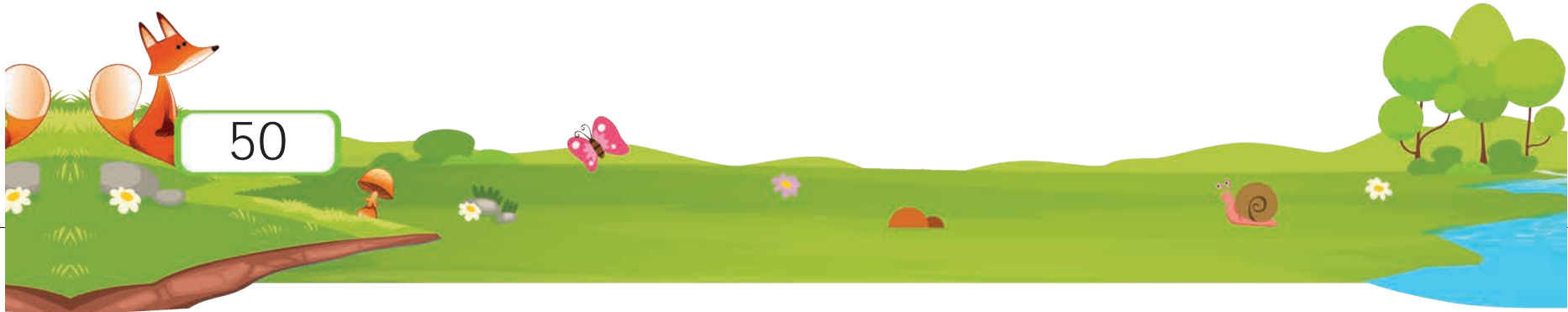

# 1. Myself



## All About Me

Paste your picture and fill in the blank with the help of your teacher/parent.

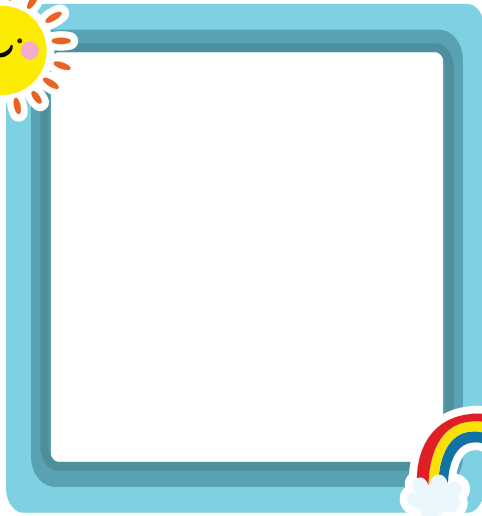

I am  years old.

I am a \_\_\_\_\_ . (girl/boy)



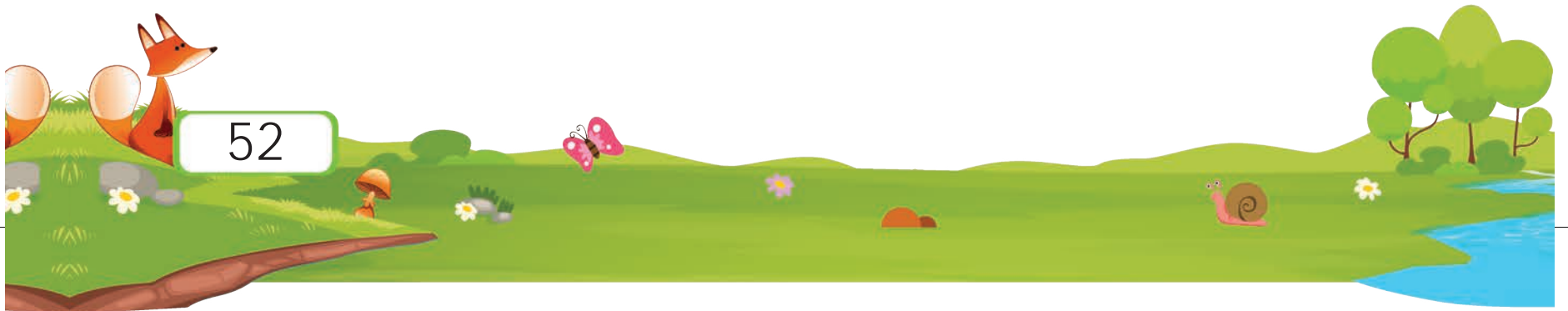



## Complete the Picture

Are you a boy or a girl? Stick the correct dress and hair to complete the picture given below. Use the sticker page at the end of the book to complete this activity.

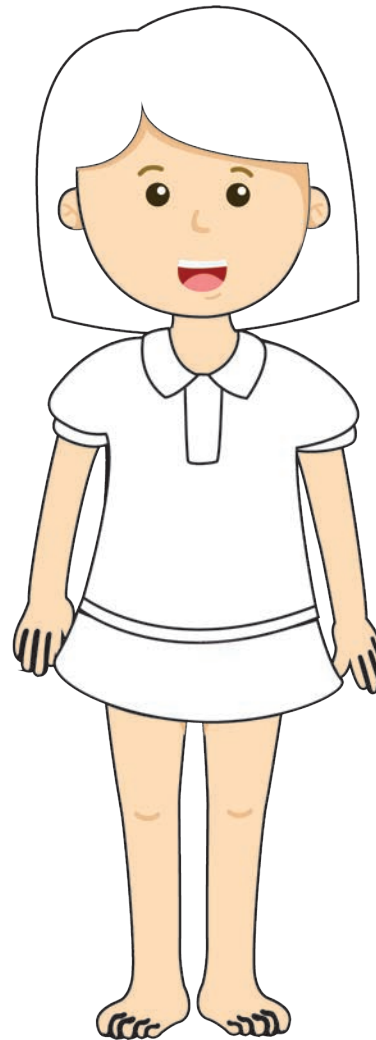
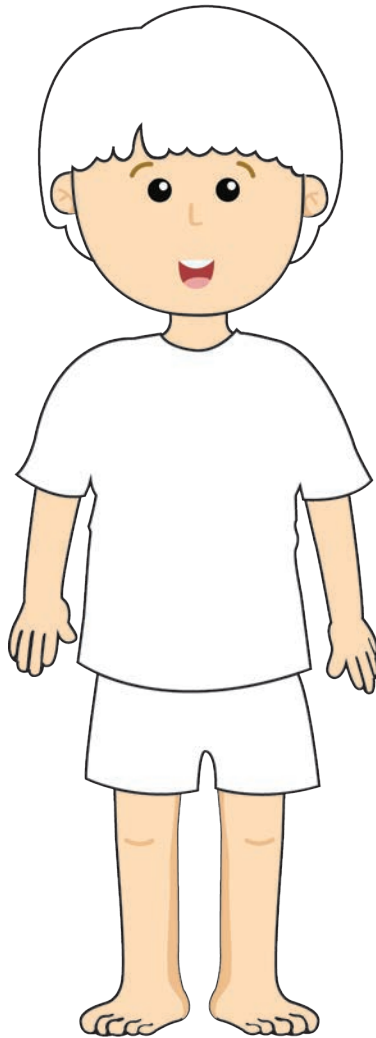

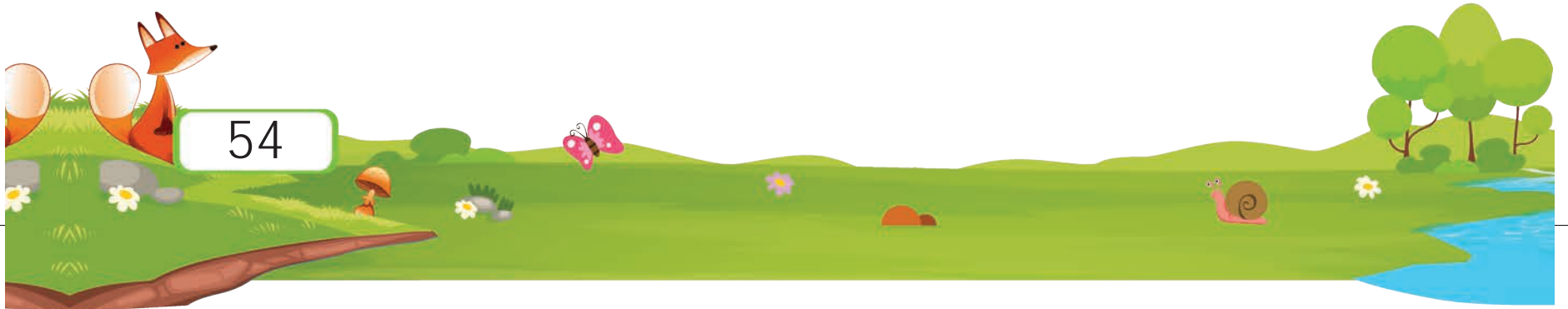



## Stick Things You Like

Paste the stickers of the things you like in the space given below. Use the sticker page at the end of the book to complete this activity.

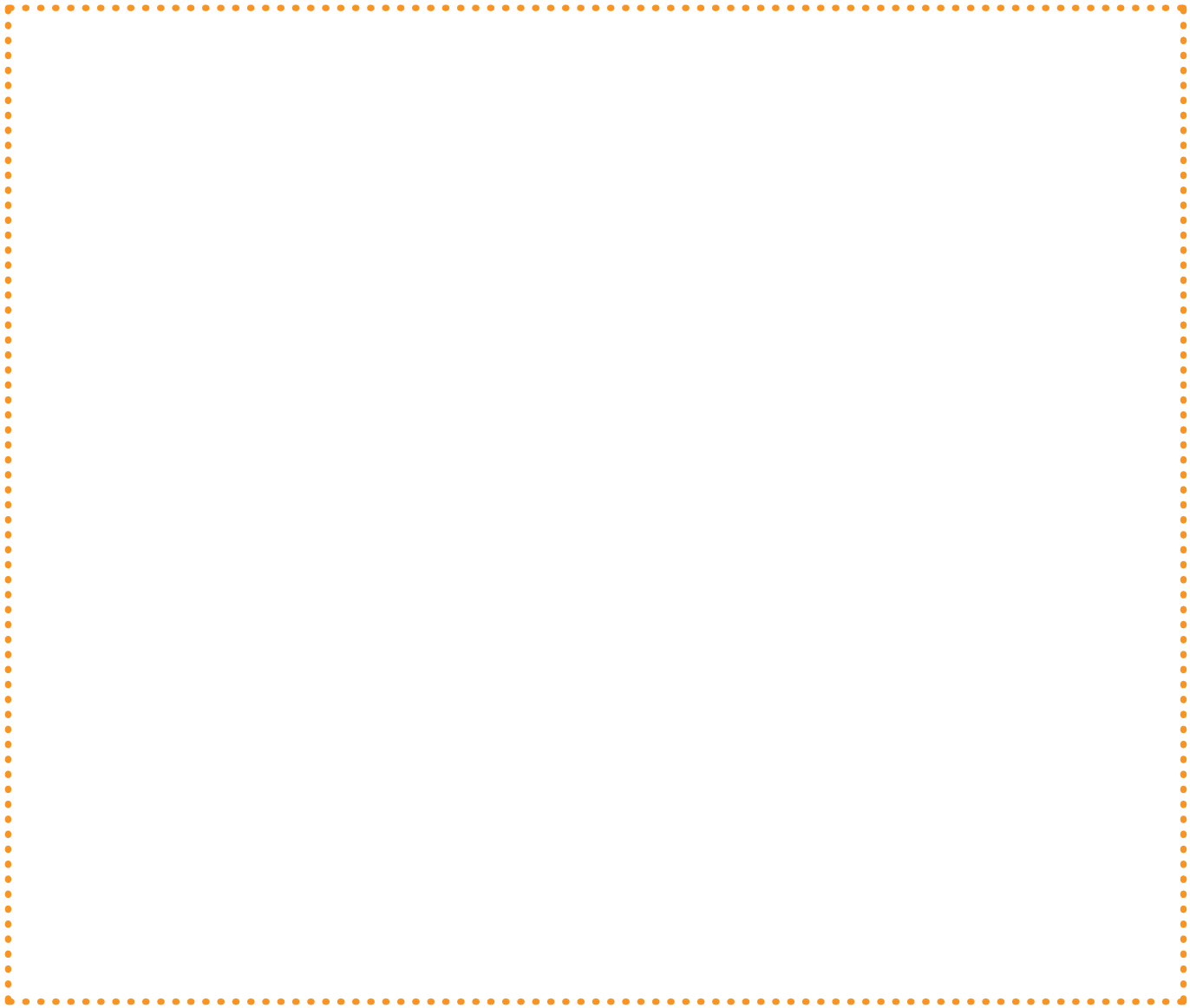

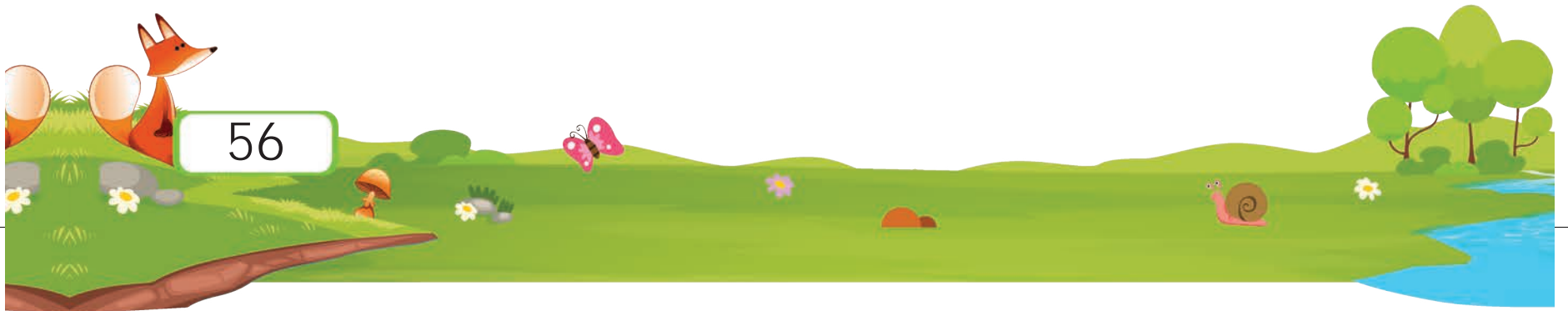

56

## 2. My Family



### Cut and Paste Matching Family Members

Look at the picture of the family. Cut pictures of people who match the family members from the next page. Then, paste them in the given boxes.



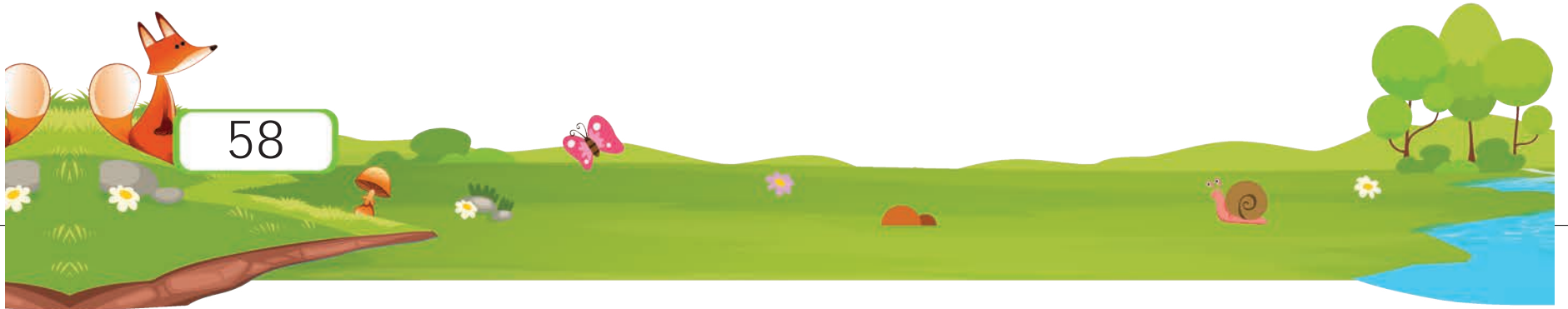

58



Cut the images below and paste them next to the matching person given on the previous page.



Mother



Grandmother



Father

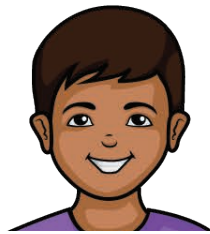

Brother



Sister

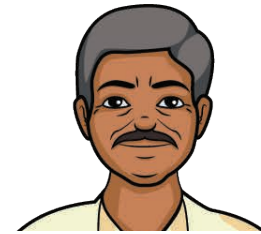

Grandfather



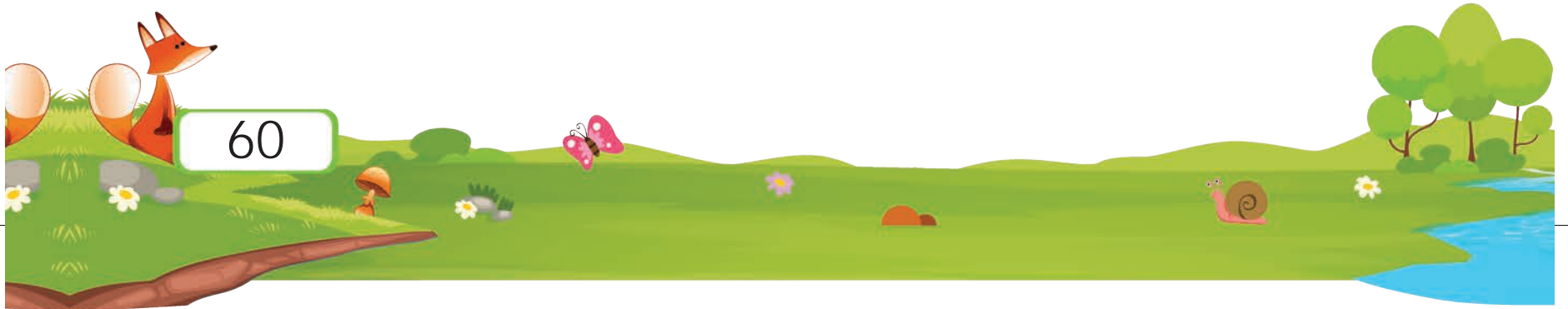

# 3. My Body



## Paste Matching Stickers

Identify the parts of the body shown in the picture. Paste stickers of actions that match these body parts. You can use the stickers given on the last page of this book.

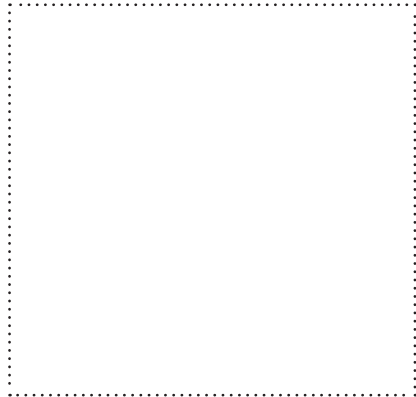

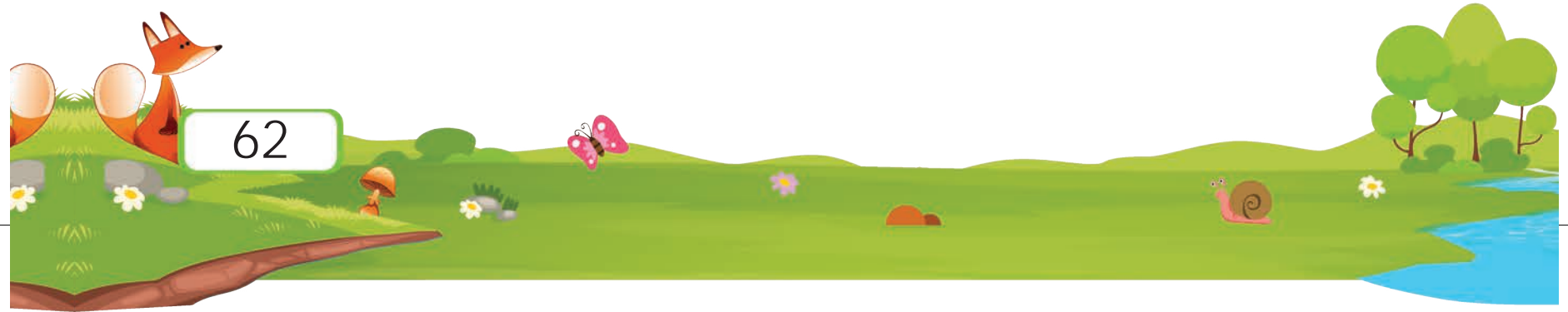

62

## 4. My School



### Colour the Objects in Classroom

Look at the picture and colour the objects that you see in your classroom.

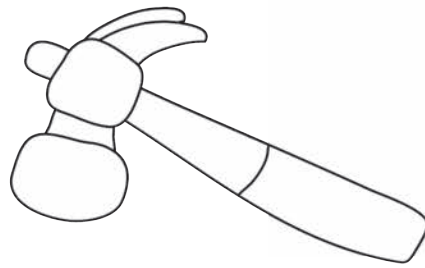
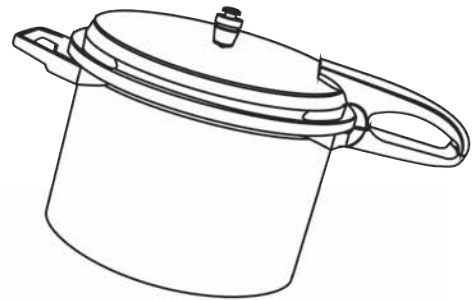
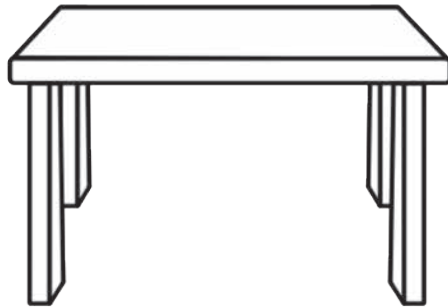
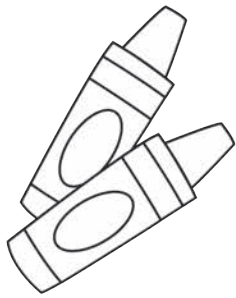

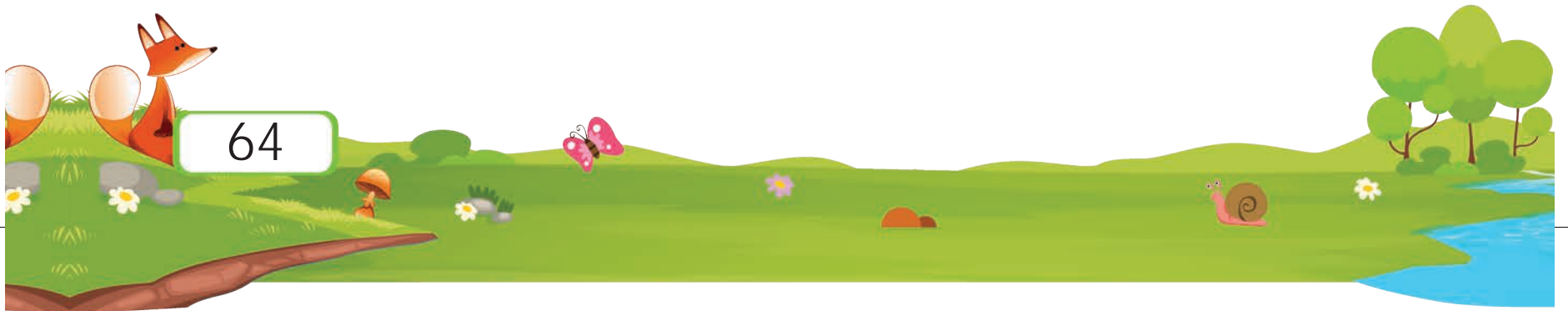

## 5. Places Around



### Colour the Answer

Each set has two objects. Look at the questions given for each set and colour the answer.

Which one is available in the market?

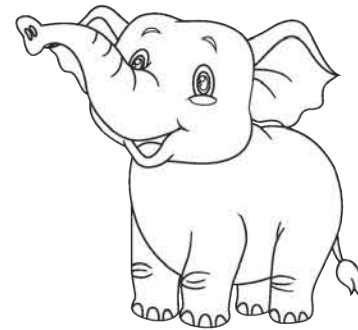

Whom do you see in a school?

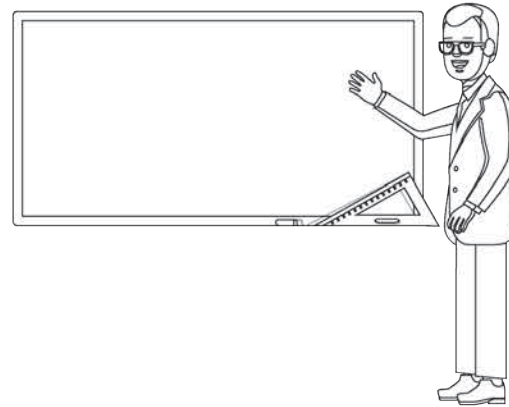

Where do you go if you are hurt?



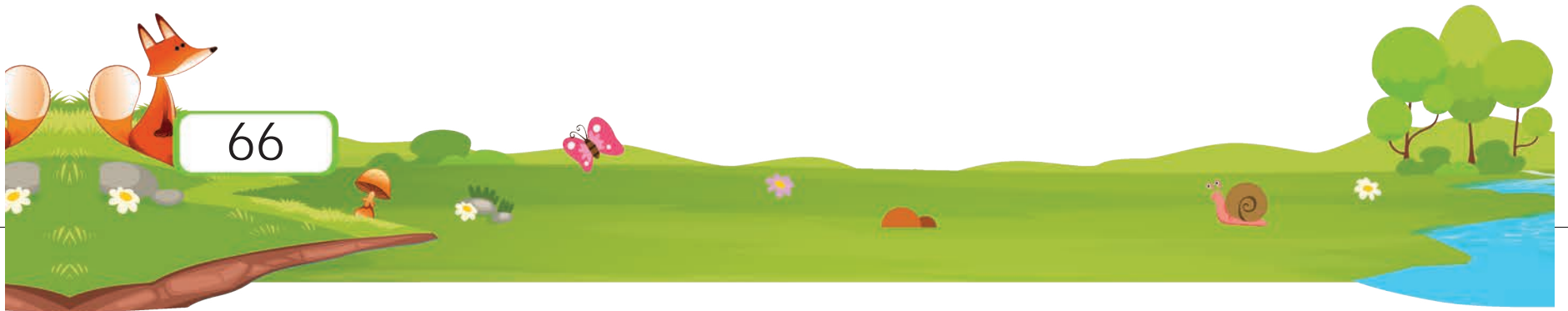

66

## 6. My Country



### Complete the National Flag

Cut and paste the coloured strips from the next page to form the tricolour flag.

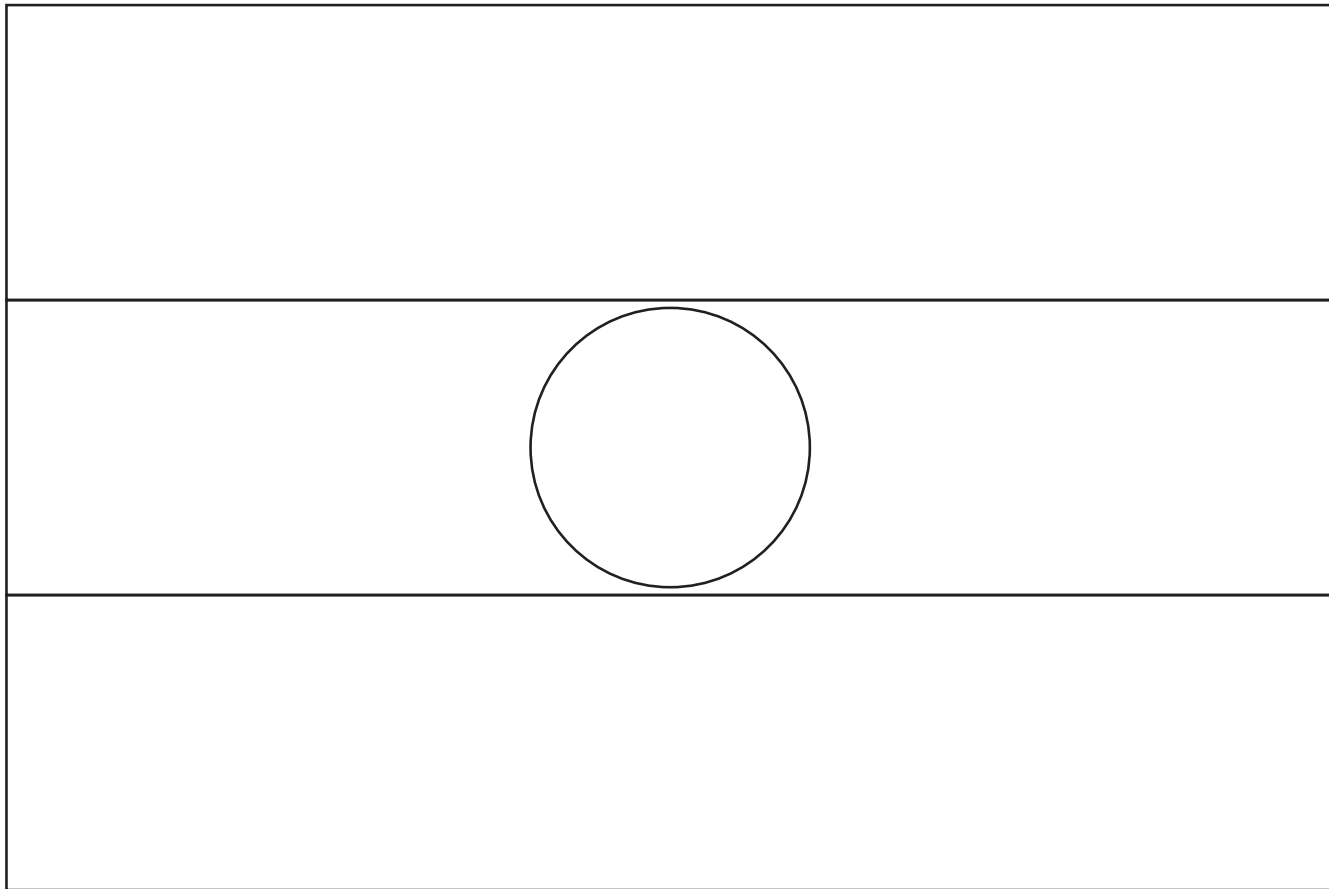

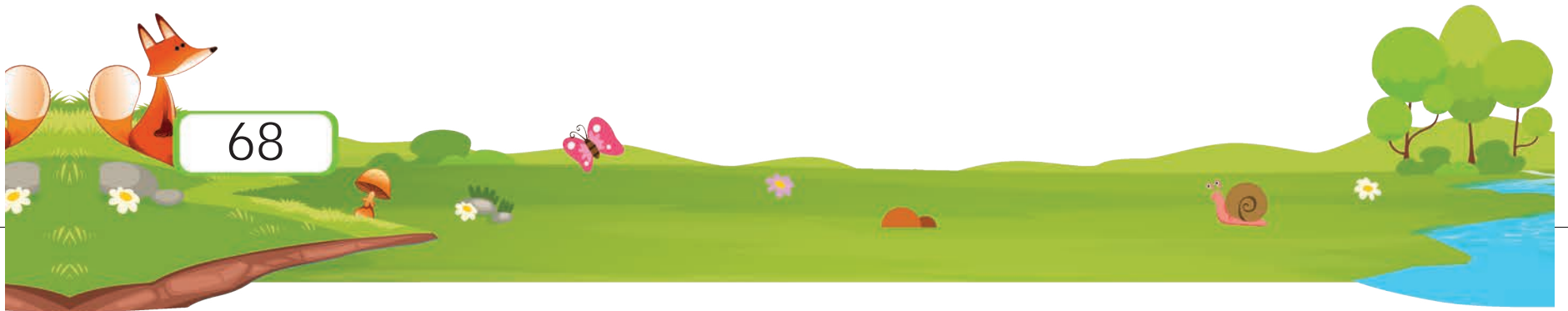

68



Cut the coloured strips and paste them on the previous page to form our flag.



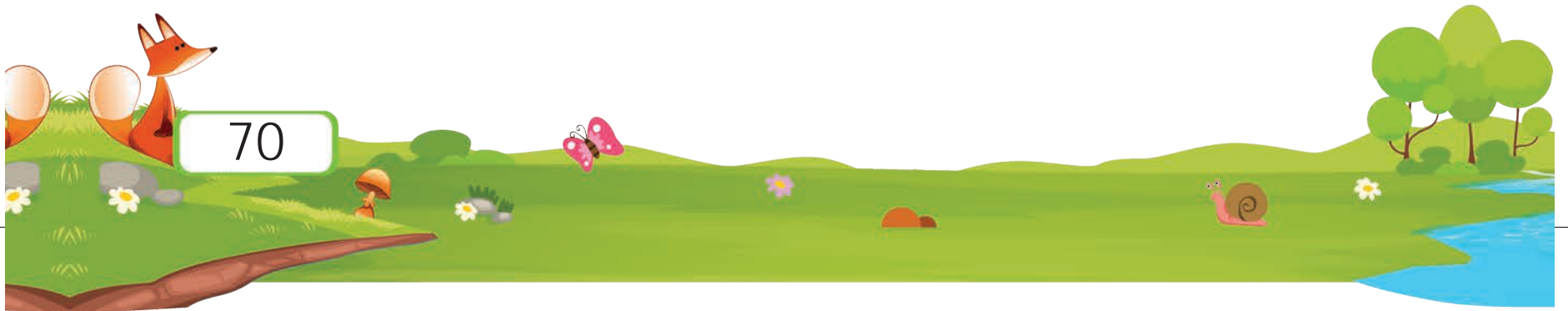

70

# 7. Cleanliness



## Colour the Good Habit

Colour the child with the good habit.

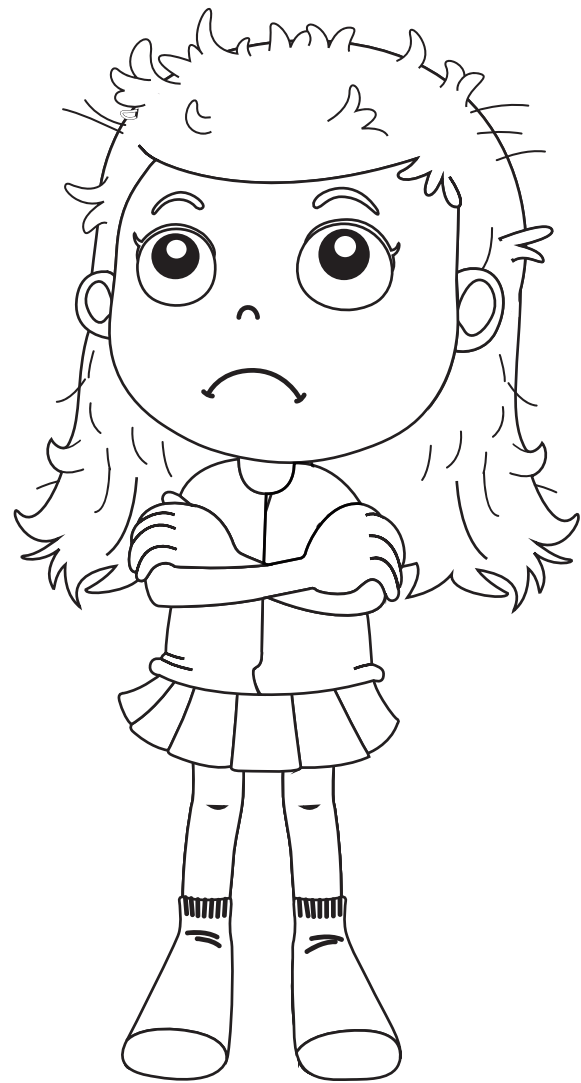

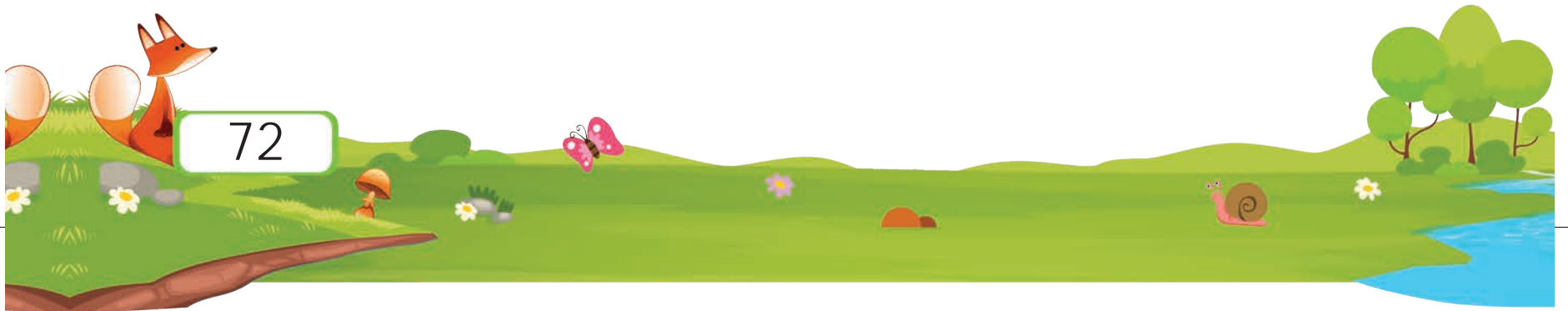

72





## 8. Healthy Food

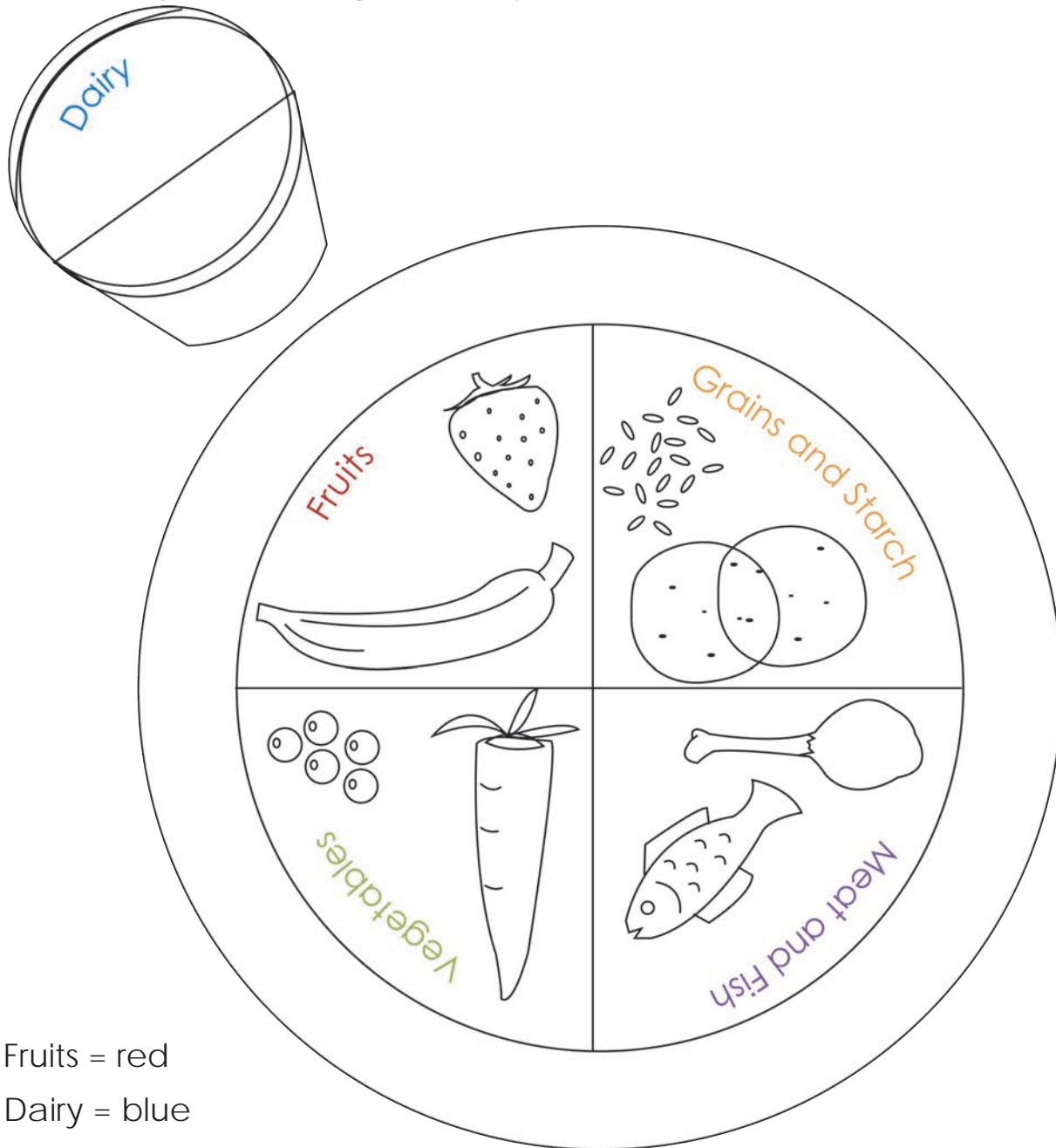

### Colour the Healthy Plate

Look at the plate to know how much of each kind of food you should eat for a healthy meal. Colour each part by following the key.



-  Fruits = red
-  Dairy = blue
-  Meat and fish = purple
-  Veggies = green
-  Grains and starch = orange

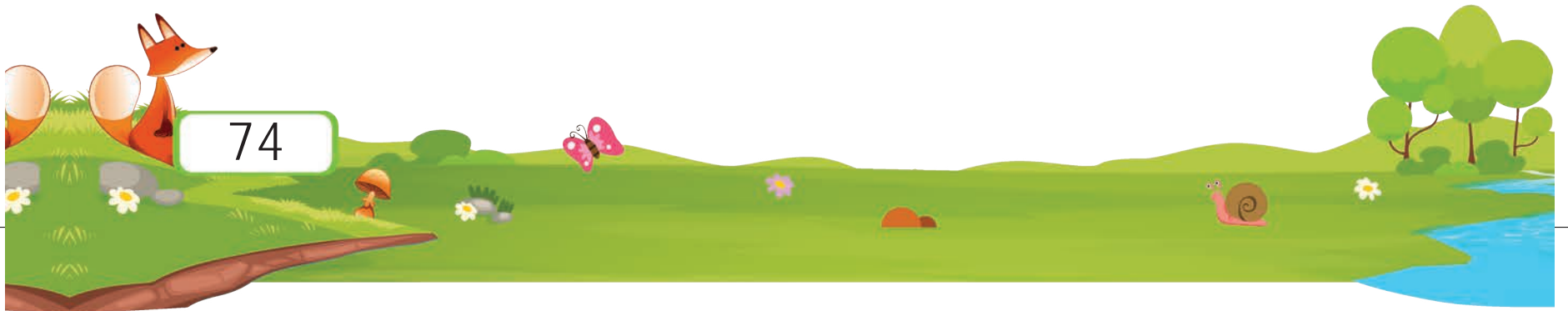

74

# 9. Day and Night



## Colour and Sort Activities

Colour the box in yellow for the pictures related to DAY. Colour the box black for the pictures related to NIGHT.

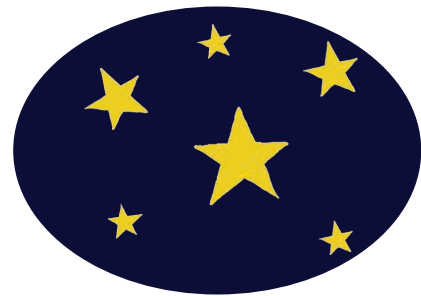
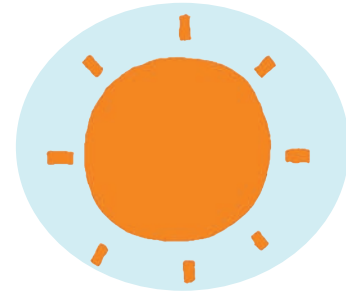

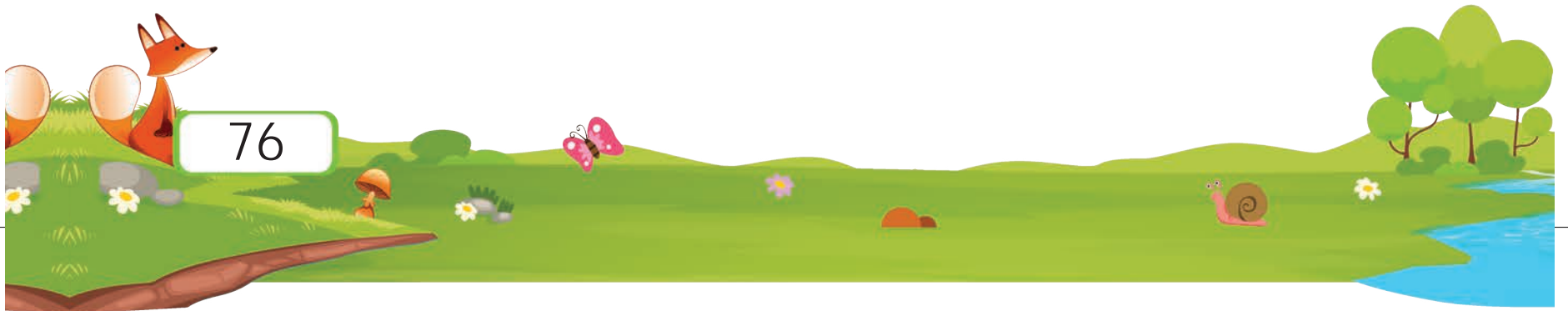

76

# 10. Good Manners



## Colour and Mark the Golden Word

Look at the situation. Colour the golden word to be used in this situation



You have broken your friend's toy.

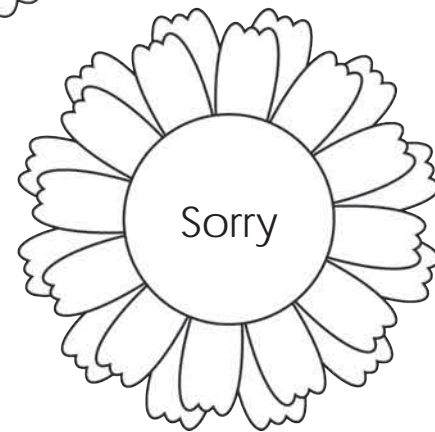
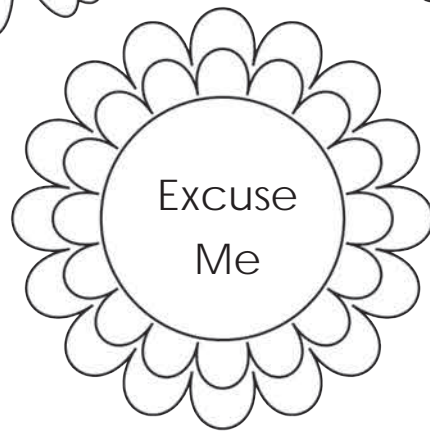
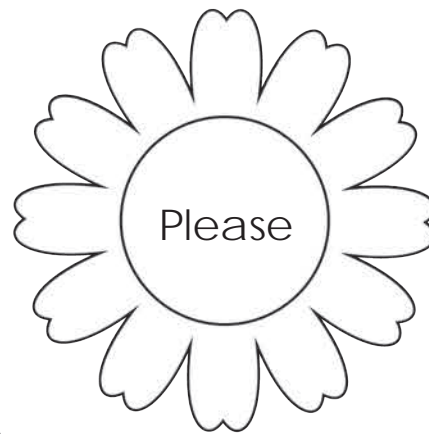

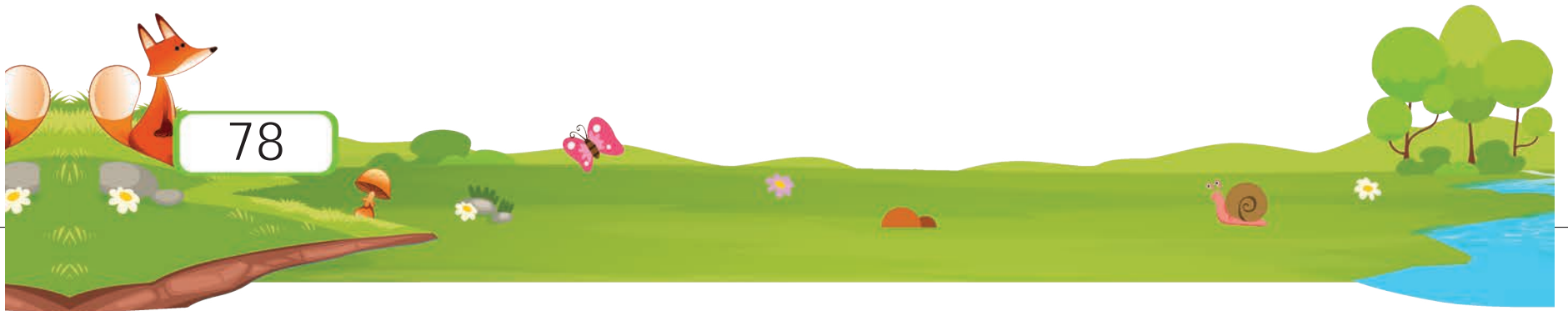

78

# 11. Water



## Collect and Paste Pictures

Paste any four pictures that show the uses of water.





80